

1965-67
GTO

Truomod

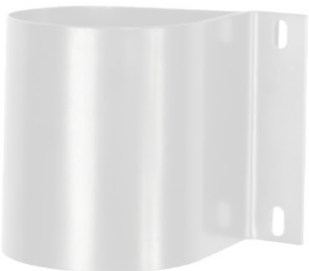
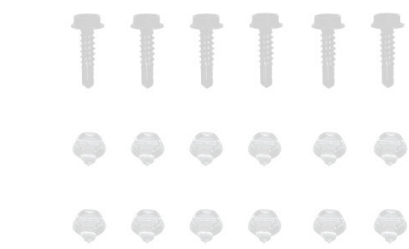

INSTALL MANUAL
©2020 RESTOMOD AIR

1965-67 GTO

CONTROL

- Mount the Stealth A/C Control as shown

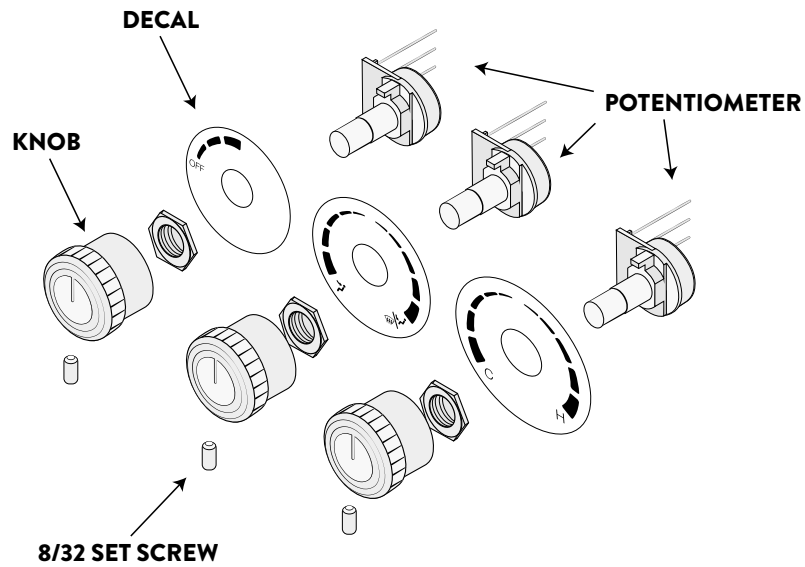

DEFROST DIFFUSER

- Remove the OEM defrost assembly.
- We've included a template for modifying the main defrost assembly. Cut out the template and tape to the assembly, then carefully cut the assembly as shown.
- Wrap foam around the opening as shown.
- Attach defrost adapter over duct as shown using two #10 x 5/8" PHP screws.
- Reinstall defrost duct using original hardware.
- Attach flex hose to the defrost defuser adaptors using zip-ties.

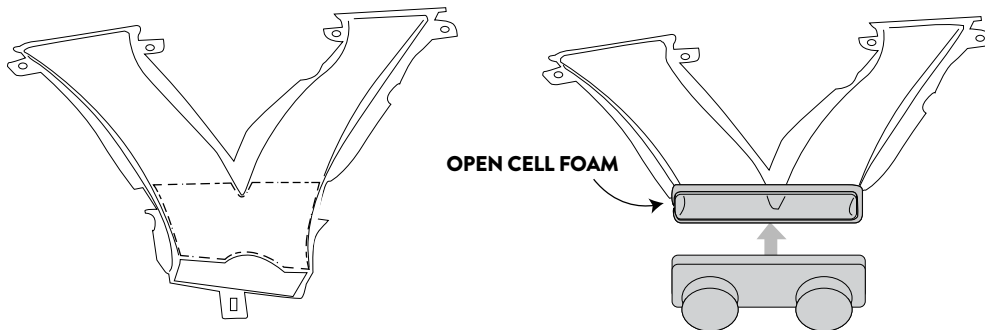



PLANNING INSTALL

Since this is a custom installation, many of our procedures can be viewed as suggestions. Your personal preferences will play a major role in the actual installation.

LOCATION OF THE CONDENSER

Condenser is purchased separate. Make sure you have the largest possible size condenser for your vehicle. Surface area is important for maximum cooling. Rule of thumb is condenser size matches the "finned" area of the radiator.

- condenser needs to be mounted in a location where hoses can reach
- should be within 1" from radiator without touching
- condenser has 2 fitting connection: larger #8 connection on top, smaller #6 on bottom.

Fab condenser mounting brackets to minimize condenser movement. Can be mounted w/fitting connections on passenger/driver side. You can not lay down condenser flat/parallel to the ground. The oil within the system is heavier & thicker than refrigerant gas. The gas separates leaving the oil trapped in the condenser, ultimately starving the compressor of lubrication.

TIP Failure to mount condenser with large fitting on top will result in system functioning incorrectly.

LOCATION OF DRIER

- drier needs to be mounted in a location where hoses can reach. Refrigerant hoses from condenser & evaporator must connect to it.
 - drier mounts vertical with connections on top. Threaded connection labeled "IN" will connect to the lower connection of the condenser.
 - do not leave drier open longer than a couple minutes. Doing so will require the drier to be replaced.
 - the drier has a location for the pressure switch/trinary switch to thread into.
- Receiver/driers are located in the high-pressure section of the system, usually in the plumbing between the condenser outlet & the expansion valve inlet, although some may be connected directly to the condenser.

They serve 3 very important functions:

1. They act as a temporary storage container for oil & refrigerant when neither are needed for system operation (such as during periods of low cooling demand). This is the "receiver" function of the receiver/drier.
2. They trap very small debris that may be inside the a/c system.
3. They contain desiccant. The desiccant is used to absorb moisture that may have gotten inside the a/c system during manufacture, assembly or service. Moisture can get into the a/c components from humidity in the air. This is the "drier" function of the receiver/drier.

Damage can occur if there is excessive moisture inside an a/c system. It can cause corrosion, as well as possibly degrade the performance of the compressor's lubricating oil.

The receiver/drier should be replaced any time the system is opened for service, and most compressor warranties require it. The desiccant is only capable of absorbing a certain amount of moisture, and when the inside of the system and/or the receiver/drier are exposed to the atmosphere, the desiccant can become very quickly saturated from humidity in the air. If this occurs, the desiccant is no longer effective, and will not provide future protection. Additionally, the filter inside the receiver/drier could be restricted by debris that may have been inside the system. This could diminish refrigerant and oil flow.

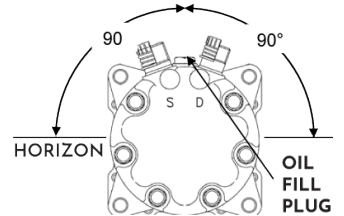
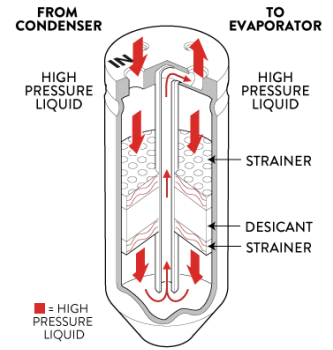
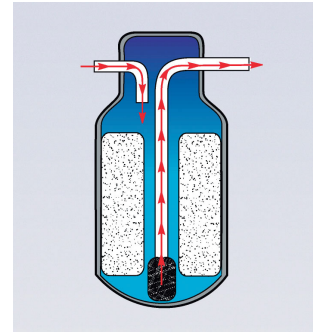

LOCATION OF COMPRESSOR

Use installation instructions provided by your engine bracket manufacturer.

TIP Most brackets mount compressors either passenger or driver side.

TIP Compressor fittings cannot be mounted with fittings downward

LOCATION OF HOSES

- make certain hoses have enough slack when connecting to compressor so that fittings do not prematurely fatigue w/engine vibrations
- make certain hoses are secured with supplied clamps so hoses don't rub against objects
- hose fittings must be crimped by a reputable service center or can be sent back to us.
- hydraulic crimping cannot be used, automotive a/c crimping dies are only suitable for refrigerant barrier hoses.

TIP When inserting hose into fitting, make certain hose can be seen in relief hole.

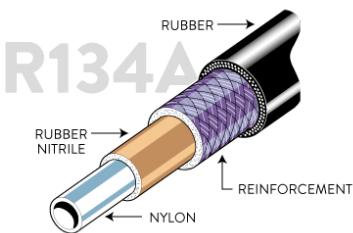

HOSE REFERENCE	
SIZE	HOSE
5/16"	#6 Liquid Hose
5/8"	Heater Hose
13/32"	#8 Discharge Hose
1/2"	#10 Suction Hose



INSTALL CHECKLIST

✓	PAGE	DESCRIPTION
<input type="checkbox"/>	01-02	Plan your install
<input type="checkbox"/>	04	Attach condenser brackets
<input type="checkbox"/>	04	Mount condenser
<input type="checkbox"/>	05	Attach pressure switch & wiring harness into drier
<input type="checkbox"/>	05	Insert drier into mounting bracket
<input type="checkbox"/>	06	Attach hoses



CONDENSER BRACKETS

Use provided brackets or fab your own from mounting points. Secure condenser to minimize movement.

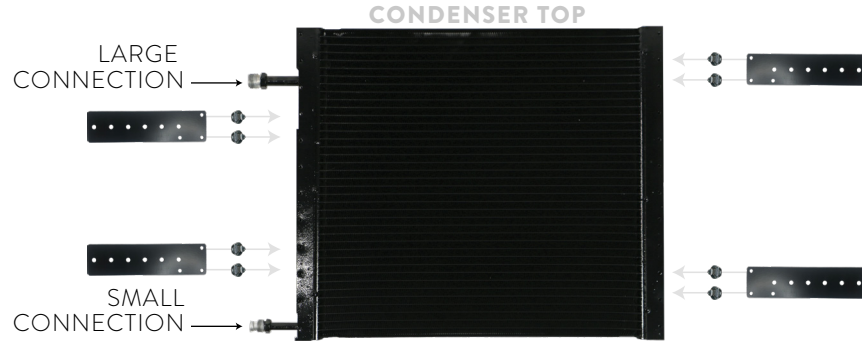

CONDENSER MOUNTING

Place condenser in front of radiator within 1". Mount to radiator support with self tapping screws. Some condensers have mounting points on the top.

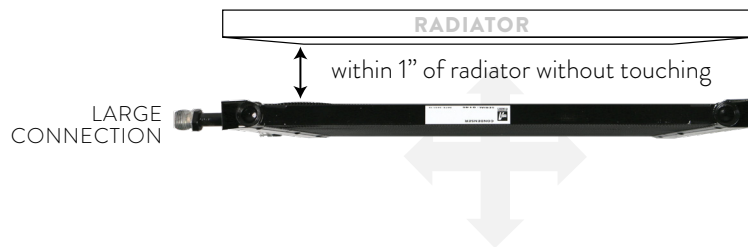

O-RINGS

When installing o-rings on the hose connections, be certain the o-ring is properly sealed. Also check for sharp edges on the seat. If installed wrong, or the seat has a sharp burr, the o-ring can be cut.

TIP Use the o-ring pack supplied. Not all sizes and quantities will be used.

IMPORTANT

- Use 2 wrenches to tighten fittings.
- Do not over tighten.
- Use a few drops of mineral oil with every o-ring.
- Crushing or ripping an o-ring will create a small leak very difficult to locate.

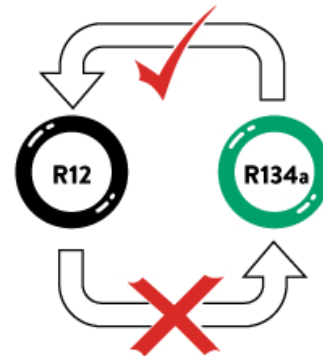
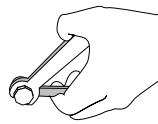

DRIER + PRESSURE SWITCH

PRESSURE SWITCH/SAFETY SWITCH (SINGLE SWITCH)

Remove the dust cover on the pressure switch and attach wiring harness to electrical connections. If properly installed, it will not allow the compressor to engage if too little or too much refrigerant.

Pressure switch is a compressor safety switch designed to save the compressor from failure due to too low or too high of pressure in the system.

LOW	HIGH
28 PSI	380 PSI

	PRESSURE	SWITCH
RED	0-27 PSI	OPEN (OFF)
GREEN	28-380 PSI	CLOSED (ON)
RED	381+ PSI	OPEN (OFF)

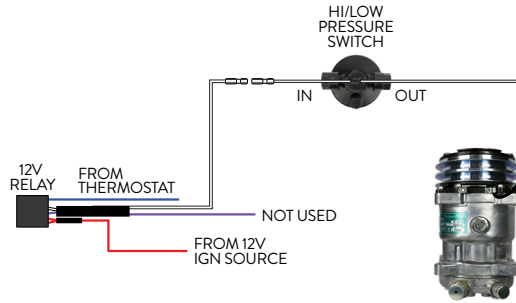
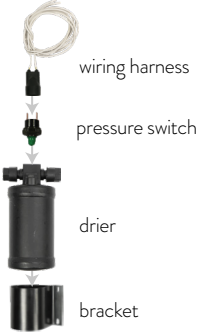

TRINARY SWITCH (DUAL SWITCH)

Trinary switches combine low and high pressure compressor clutch cut-off functions plus an electric fan engagement signal at 254 psi.

	PRESSURE	SWITCH
RED	0-27 PSI	OPEN (OFF)
GREEN	28-380 PSI	CLOSED (ON)
RED	381+ PSI	OPEN (OFF)

	PRESSURE	SWITCH
RED	0-253 PSI	OPEN (OFF)
GREEN	254+ PSI	CLOSED (ON)

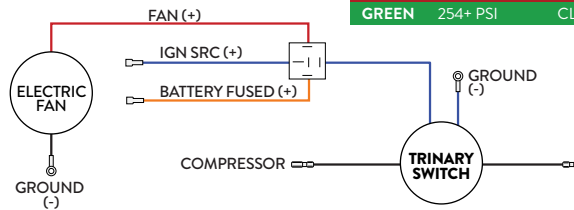

RELAY NOT SUPPLIED - PURCHASED SEPARATELY

DRIER

When removing caps, pressure will release. Do **NOT** leave drier open to air longer than a couple minutes. Mount drier in a location where the hoses can reach.





HOSE ROUTING

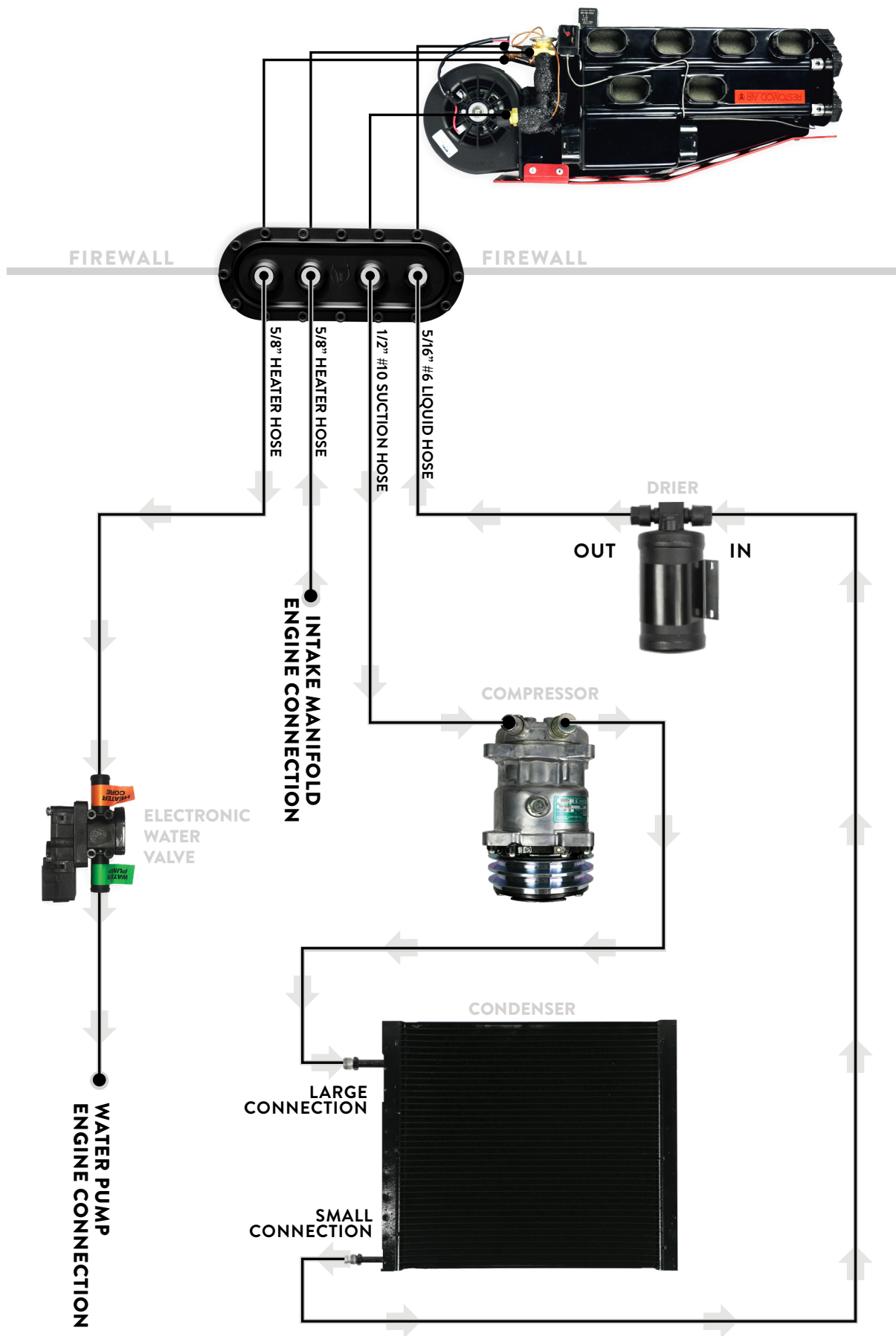

DEFROST DUCT TEMPLATE

CUT LINE

CUT LINE

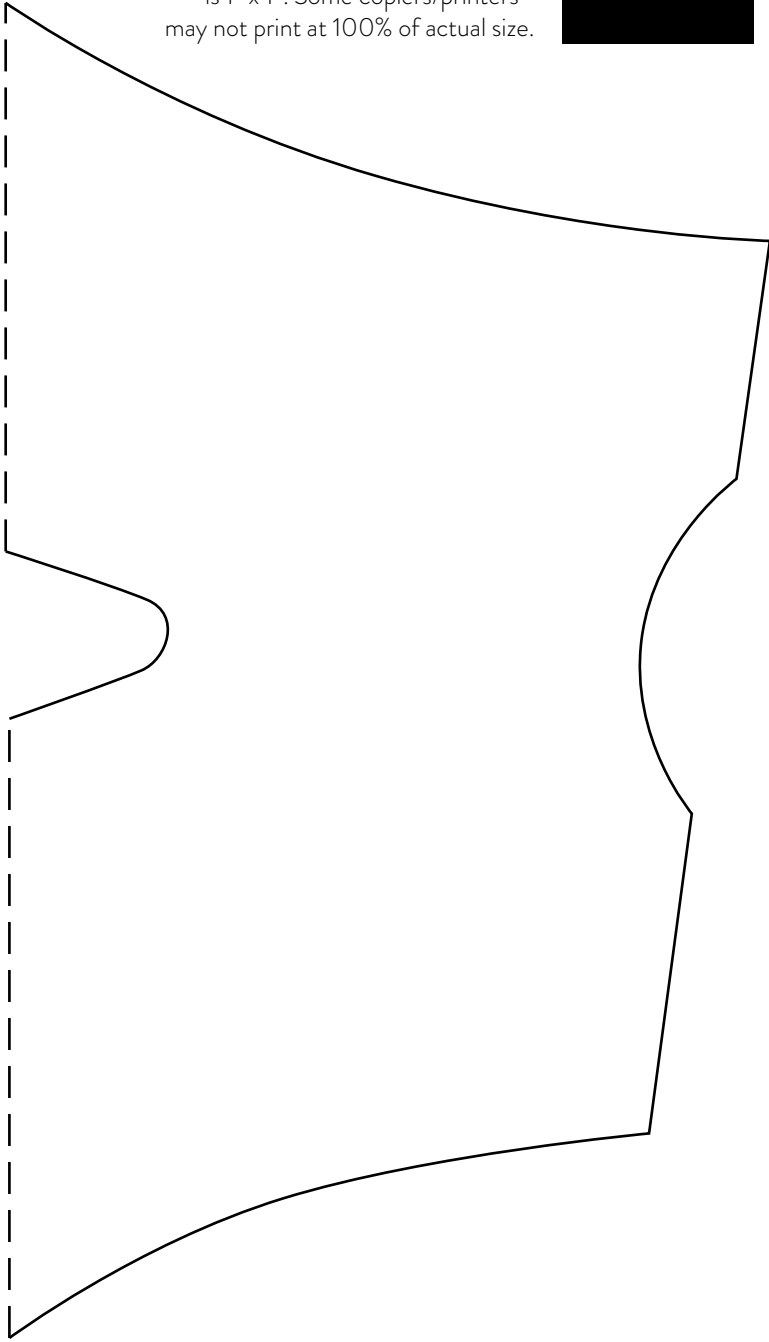

**IF YOU PRINTED THIS MANUAL
PLEASE READ THIS...**

Just as a cautionary step, please measure this box and make sure it is 1" x 1". Some copiers/printers may not print at 100% of actual size.

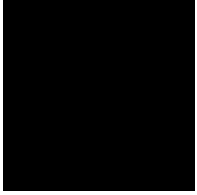

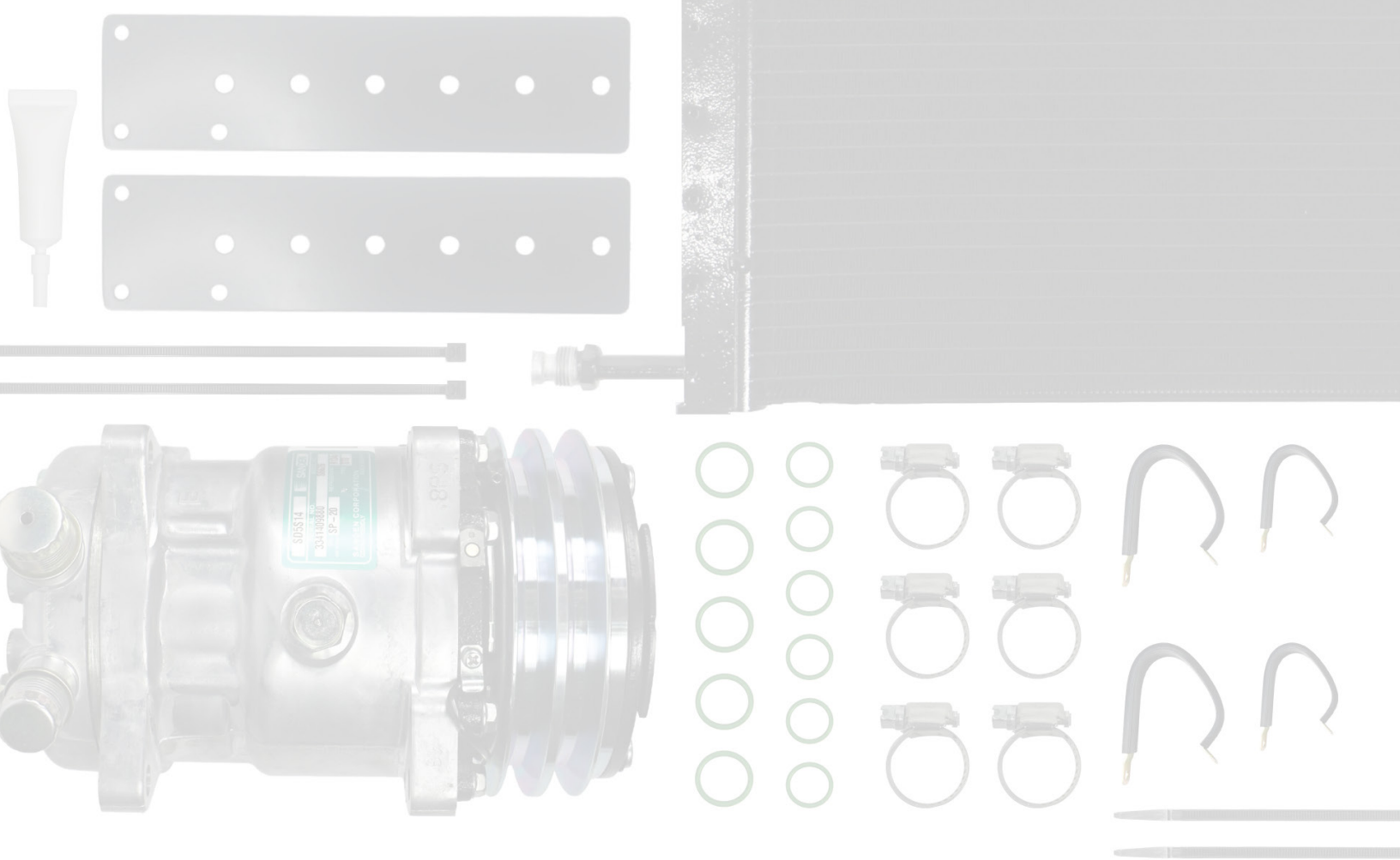

Truomod

