



Custom Fit

Air Conditioning Kit

1988-94 CHEVY TRUCK - FACTORY AIR

INSTALL MANUAL

RM-1-3097FA V01.0
© 2025 RESTOMOD AIR

INSTALL CHECKLIST

✓	PAGE	DESCRIPTION
<input type="checkbox"/>	02-03	HAYMAKER-S OVERVIEW
<input type="checkbox"/>	04-05	PLAN YOUR INSTALL
<input type="checkbox"/>	06-08	HAYMAKER-S MOUNTING
<input type="checkbox"/>	09	DRAIN TUBE
<input type="checkbox"/>	10	MODEL SPECIFIC HOSES
<input type="checkbox"/>	11	ELECTRIC WATER VALVE
<input type="checkbox"/>	12	BLOCK OFF & HEAT DUMPS
<input type="checkbox"/>	13	WIRING
<input type="checkbox"/>	14	ECU OVERVIEW
<input type="checkbox"/>	15	APP OVERVIEW
<input type="checkbox"/>	16-18	CONTROLS
<input type="checkbox"/>	19-26	VENT INSTALLATION
<input type="checkbox"/>	27-31	MODEL SPECIFIC CONDENSER INSTALLATION
<input type="checkbox"/>	32-33	MODEL SPECIFIC TUBES & HOSES
<input type="checkbox"/>	34-35	CUSTOM FIT CONDENSER INSTALLATION
<input type="checkbox"/>	36-37	CUSTOM FIT HOSES
<input type="checkbox"/>	38	PRESSURE SWITCH

HAYMAKER-S OVERVIEW

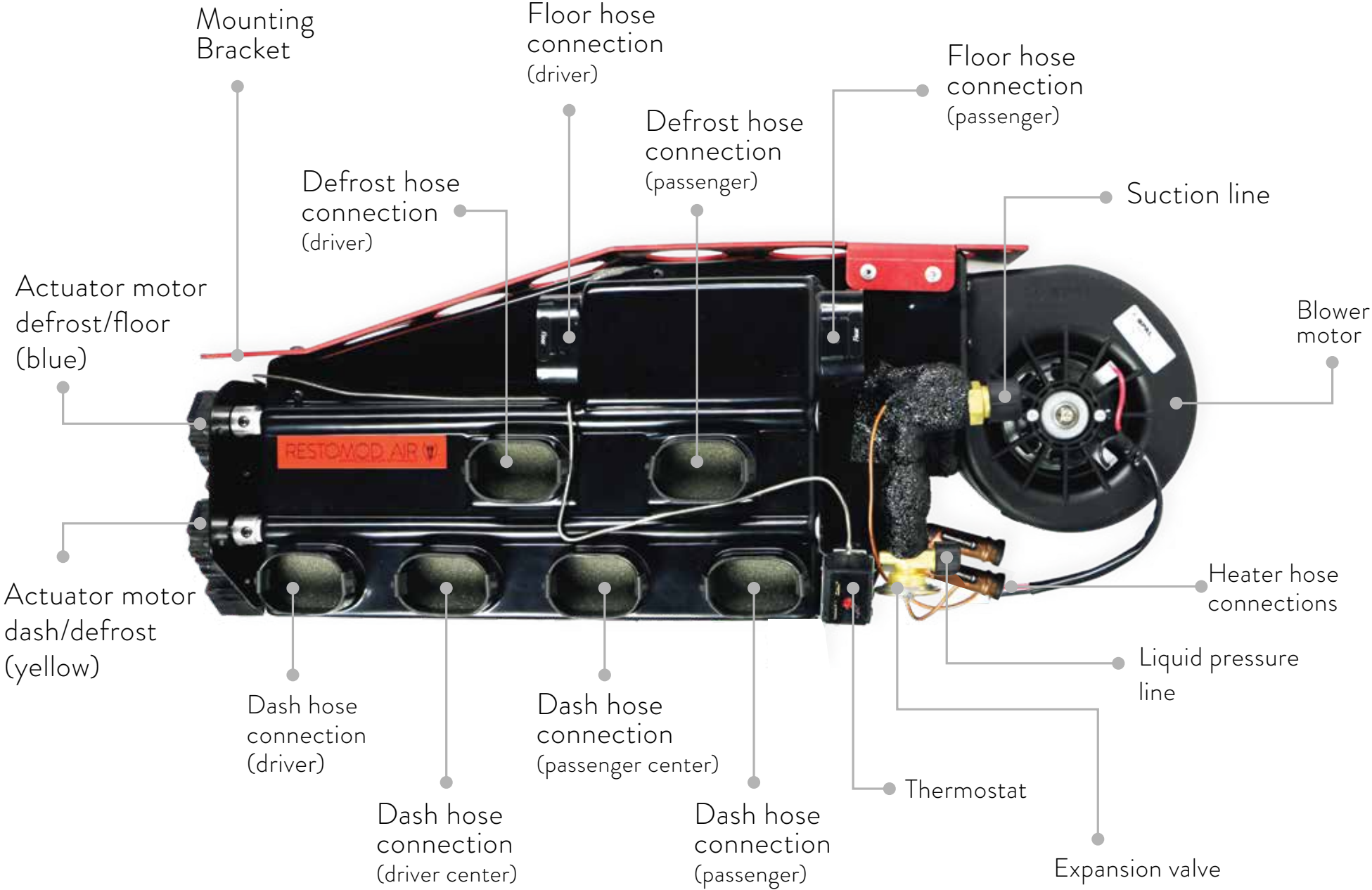

HAYMAKER-S FEATURES

The Haymaker-S is made specifically for full-size vehicles with large interiors.

CHANGING AIR POSITIONS

The Haymaker-S allows for blending air positions and temperatures. When turning mode knob clockwise, air will blend from dash to defrost by activating the yellow servo motor. When continuing the rotation of the knob clockwise, the air will blend from defrost to floor by activating the blue servo motor.

CHANGING AIR TEMPERATURES

When turning temp knob clockwise, temperature will increase from cold to hot. Like modern vehicles, the compressor is active in all mode positions to allow temperature blending by adding heat with the temperature knob. Compressor is off in full heat position.

MULTI-MOUNT

Our exclusive multi-mount system allows you to mount your Haymaker-S without the need to fab any bracket for your firewall with 4 different options. If your firewall has a indentation for the trans tunnel, use the included multi-mount extension bracket to offset your unit.

BLUETOOTH

The Haymaker-S works with your mobile device by establishing a secure Bluetooth connection to provide instantaneous wireless control and feedback. Download the app from the Apple app store or Google Play store.

SWITCH TECHNOLOGY

Switch Technology allows you to bounce back and forth between the app, hard control and remote controls. Yes, you can have multiple ways to control your Haymaker-S.

PLANNING INSTALL

If your vehicle has been or is being modified, some procedures will need to be adjusted to fit your particular application. Read below before cutting/drilling. Since this is a custom installation that will vary based on your particular vehicle, many of our procedures can be viewed as suggestions. Your personal preferences will play a major role in the actual installation.

LOCATION OF THE UNIT

The Haymaker-S is designed for vehicles that have “flat /shaved /smoothed” firewalls. If you have not done this you might want to make a firewall plate before starting the install.

- leave a min. of 1 1/2”-2” above unit for dash and defrost duct hose connections
- leave a min. of 6”-9” right of the unit for a/c and heater hoses to enter the engine bay
- keep in mind ECU wires are designed to mount near the a/c unit
- make sure unit is level

LOCATION OF THE DRAIN TUBE

- location of the drain tube hole must be below the unit
- use the supplied grommet + 90° elbow to create a tight seal

TIP Most custom installers will not want the water exit to be on the firewall and choose the passenger kick panel instead. Make sure water actually exits the kick panel area and it does not collect in the cavity between inner kick panel and outer fender.

IMPORTANT

Condensation forms when the compressor is active. Water exiting the evaporator uses gravity to evacuate. Water does not travel upwards.

LOCATION OF HOSES TO ENGINE COMPARTMENT

- the Haymaker-S has heater + a/c connections
- use bulkhead plate as a drill template
- if using grommets: seal around hoses tightly to prevent engine/outside air + moisture entering the cabin
- when tightening fittings, make sure to use a backup wrench
- do not overtighten fittings (o-rings will crush or tear)
- after attaching hoses to evaporator, apply refrigerant tape to hose fittings on the evaporator to keep condensation from dripping on passenger floor board
- We have supplied fittings that work for most applications but if you need a different fitting, let's swap. Give us a call.

While bulkhead plates create a visually appealing connection, they are important because they create a positive seal from engine bay conditions such as: moisture, heat and fumes. If you are not using a bulkhead, make certain to seal around hoses and use grommets to avoid premature failure caused by vibrations and friction. Seal all holes/seams or anything else that will allow engine/outside air to enter the cabin. Failing to do so will prevent a/c unit to perform at it's highest ability.

TIP If room allows, we recommend mounting heater/water control valve on the interior of the vehicle for cleaner install.

PLANNING INSTALL

LOCATION OF ECU

- ECU must be mounted near the unit with the supplied self tapping screws
Do not extend wires on (output) harness. Doing this will change resistance valves and will not allow your unit to function properly.

TIP Make sure grounds of system are amazing. An incorrectly functioning system is typically attributed to a bad grounding (engine ground, body ground, battery ground) in the vehicle wiring.

LOCATION OF CONTROLS

- locate a spot that looks killer - but also functional
- before cutting, make certain wires will connect to the ECU location
- make sure dash cavity will allow for control depth when mounted
- make sure nothing will interfere with control function

LOCATION OF DEFROST

When running defrost ducting, make certain to cycle the windshield wipers. Duct hose can be damaged by moving wiper arms.

- use supplied zip ties to secure duct hose to unit + defrost

IMPORTANT

We have several different shapes and sizes of defrost diffusers. Get the size that fits, defrost is a safety issue!

LOCATION OF FLOOR DUCTS

The Haymaker-S is designed for large vehicles so we have provided 2 floor heat dumps. Heat is non-directional so location isn't that important just make sure the air is pointed towards driver & passenger footwell. Kick panel areas are prime locations for heat dumps.

- use the supplied self tapping screws to attach to vehicle
- use supplied zip ties to secure duct hose to unit + floor ducts

LOCATION OF VENTS

- plan two vents for the driver and two vents for the passenger
- vents must be mounted where the air will be felt on passengers - odd locations such as kick panels are not ideal
- use supplied zip ties to secure duct hose to unit + vents

The location of a/c vents are the single most important decision to be made during planning & install. Remember, a/c IS directional. Placement of vents is critical to comfort for driver & passenger. The vent must be close to occupant or they will not be cool & comfortable.

TIP Adding vents does not mean better air flow and removing vents does not mean better airflow. Adding vents does not magically give you more air, life is not that simple. The Haymaker-S is engineered to use 4 dash vents. Use them.

USING THE MULTI-MOUNT

The multi-mount system allows for you to mount your unit flush with the inside smoothed/shaved/flat firewall - use the included extension mounting bracket to offset your unit if needed.

FLAT FIREWALL



CURVED FIREWALL



LARGE CURVED FIREWALL

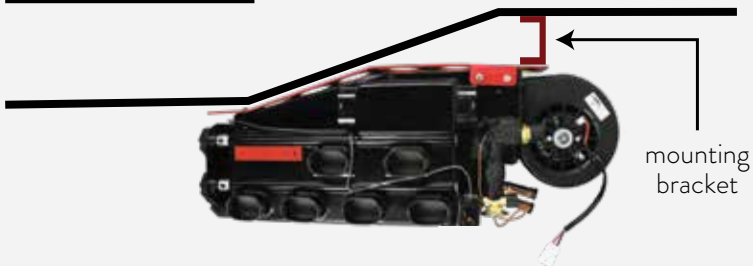

MOUNTING
POINT

MOUNTING
POINT

MOUNTING
POINT

MOUNTING
POINT



USING THE MULTI-MOUNT

STANDARD - WELD STUDS

Weld studs are provided for vehicles with unpainted firewalls. If your firewall is painted, refer to the bolt option below.

Level the Haymaker-S. Mark the mounting points of the multi mount bracket. Using the marked points, weld the mounting studs. Place Haymaker-S on the studs and secure with 1/4 x 20 nuts.

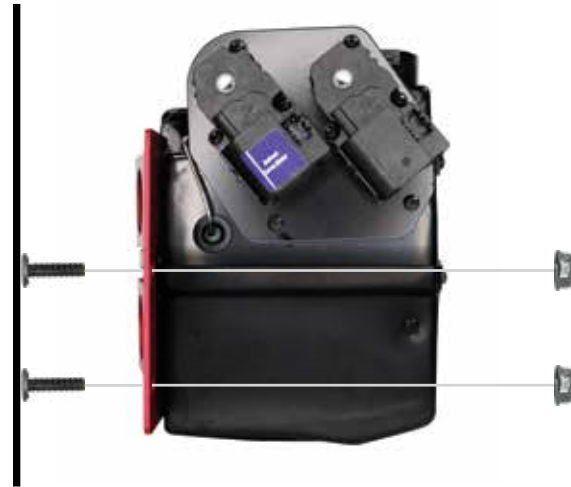

STANDARD - BOLTS

Stainless steel cap screws and flange nuts are provided for painted vehicles where installers do not mind having 4 bolt heads showing in the engine compartment.

Level the Haymaker-S. Mark the mounting points of the multi mount bracket. Using the marked points, drill the holes for the bolts. Mount the Haymaker-S using bolts.

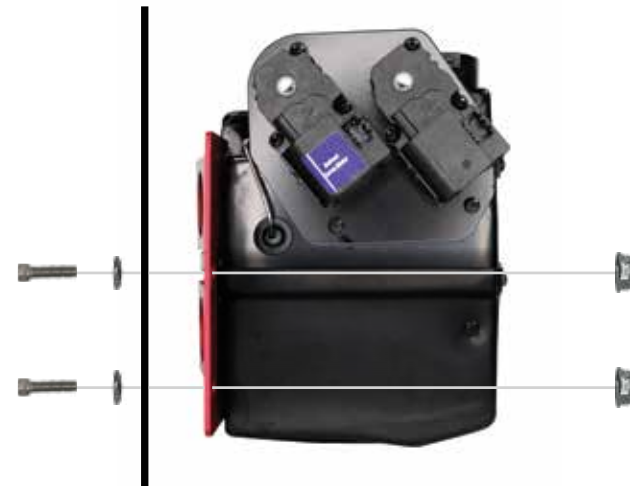

VEHICLE MOUNTING

FIREWALL MOUNTING

The most common place to mount the Haymaker-S is on the firewall behind the glove box opening. Use one of the options to mount our multi mount bracket system. Reference pages 06-07.

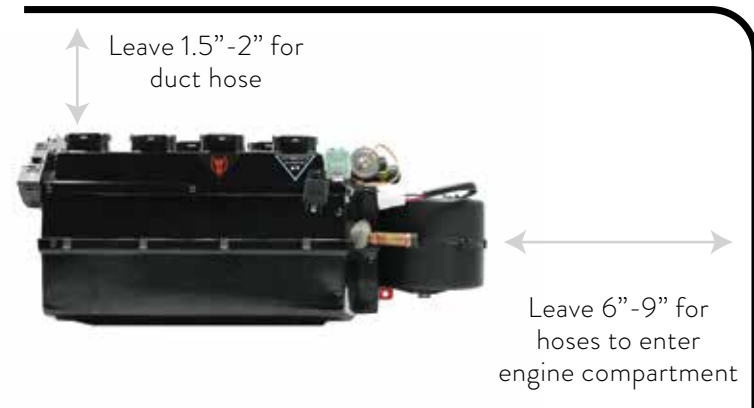

CUSTOM COWL MOUNTING

In some situations, installers do not want to mount to a painted firewall. We recommend mounting from the inner cowl area found on some vehicles. Build a bracket that will "hang" the Haymaker-S from above and secure from side to side movement. **More than one bracket will be needed.**

IMPORTANT
Beware: before mounting, make sure you are aware of what you are mounting to.

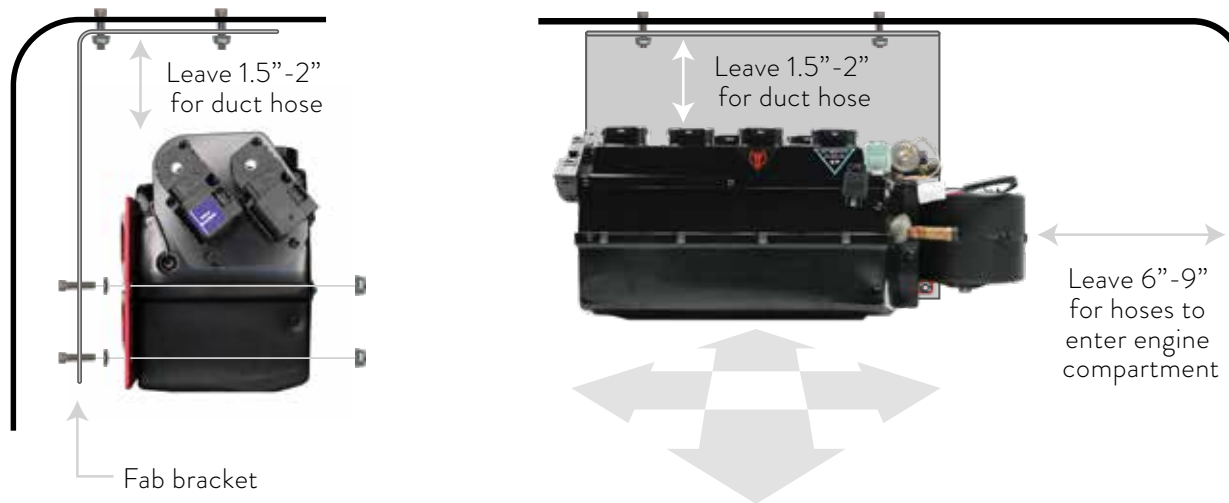

IMPORTANT
Make certain the Haymaker-S is secure from all movement.

DRAIN TUBE

FIREWALL

Locate the drain nipple on the Haymaker-S. Drill a 3/4" hole for the drain tube below the drain nipple. Attach 1/2" drain tube to evaporator nipple and run through the drilled hole. Use the supplied grommet and 90° elbow for the drain tube to exit.



KICK PANEL

Most custom installers will not want the water exit to be on the firewall and choose the passenger kick panel instead. Make sure water actually exits the kick panel area and it does not collect in the cavity between inner kick panel and outer fender.

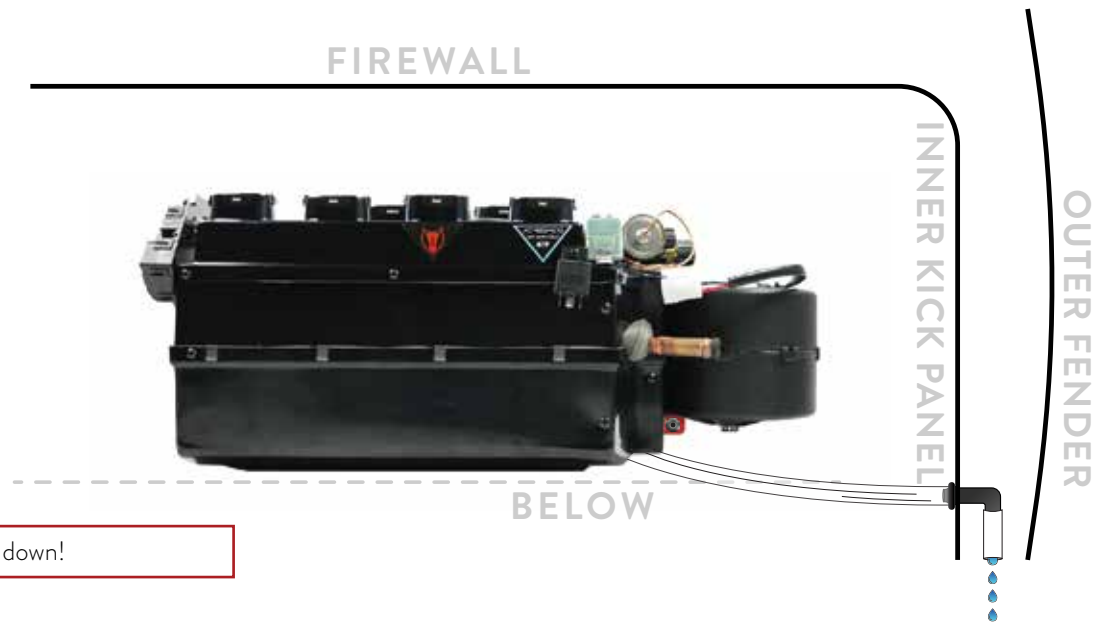

IMPORTANT

It's crucial the drain tube is angled down for water to drain - water flows down!

HOSES

FIREWALL WITH BULKHEAD/GROMMETS

Cut supplied hoses to length needed. The supplied a/c + heater fittings are for interior connections because we assume you bought one of our badass bulkheads. Use supplied large zip ties to secure hoses.

TIP Have fittings crimped by qualified shop or send back to us.



KICK PANEL WITH BULKHEAD/GROMMETS

Some installers choose to run hoses in the far fender area via the inner kick panel. Additional length hoses will be needed (not supplied.) You will have 2 seals when going through kick panel. Use supplied large zip ties to secure hoses.

TIP We recommend using grommets (not supplied) on the kick panel + bulkhead on the firewall.



IMPORTANT

- Make sure you seal all holes/seams or anything else that will allow engine or outside air to enter the cabin. Failing to do so will prevent a/c unit to perform at it's highest ability.

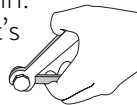

- Use 2 wrenches to tighten fittings. Do not over tighten. Use a few drops of mineral oil with every o-ring.

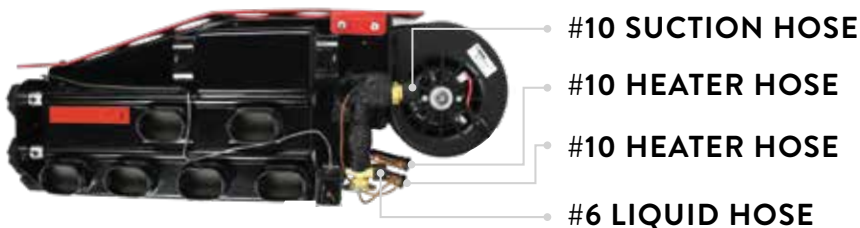

IMPORTANT

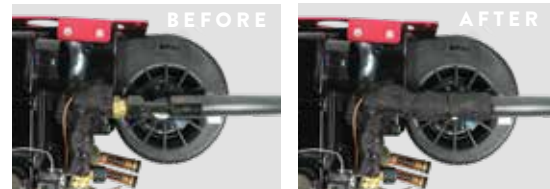

Make sure you wrap the #10 suction hose fitting on the Haymaker-S with refrigerant tape so condensation does not drip on the passenger floor board.

ELECTRIC WATER VALVE

Make sure the water valve is positioned correctly. **The water valve is a directional valve and should be installed with the arrow pointing towards the water pump.** If the water valve is connected to the incorrect hose, it allows water to circulate through the system via the heater core overpowering the cooling effect of the a/c coil. **Make certain the water valve goes to the water pump!**

IMPORTANT

It is **REQUIRED** that the water valve is on the return line and the arrow is pointed towards the water pump.



COYOTE ENGINES

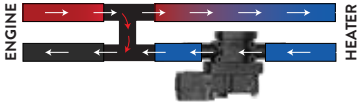

It is **REQUIRED** that the H pipe be mounted on the **ENGINE** side of the Water Valve in order to cycle water when water valve is **CLOSED**.

LS ENGINES ONLY

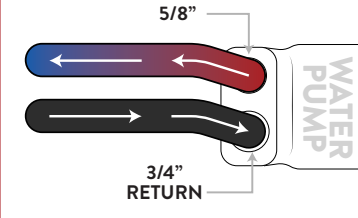

5/8"
3/4"
RETURN
WATER PUMP

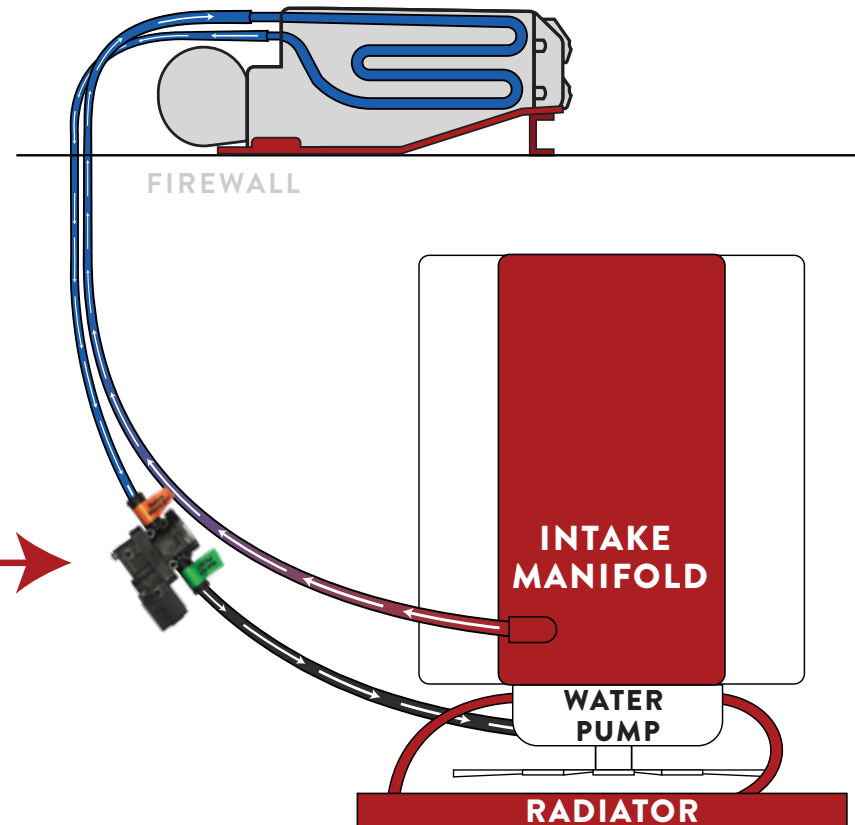

INSTALLATION - AIR BLOCK OFF, HEAT DUMPS

- Install the air intake block off assembly over the air intake using (4) #10 x 3/4" Tek screws.
- Install a heat dump near the driver's side of the transmission tunnel as shown using (2) #10 x 3/4" Tek screws.
- Install a heat dump as high as possible on the passenger's side kick panel as shown using (2) #10 x 3/4" Tek screws.

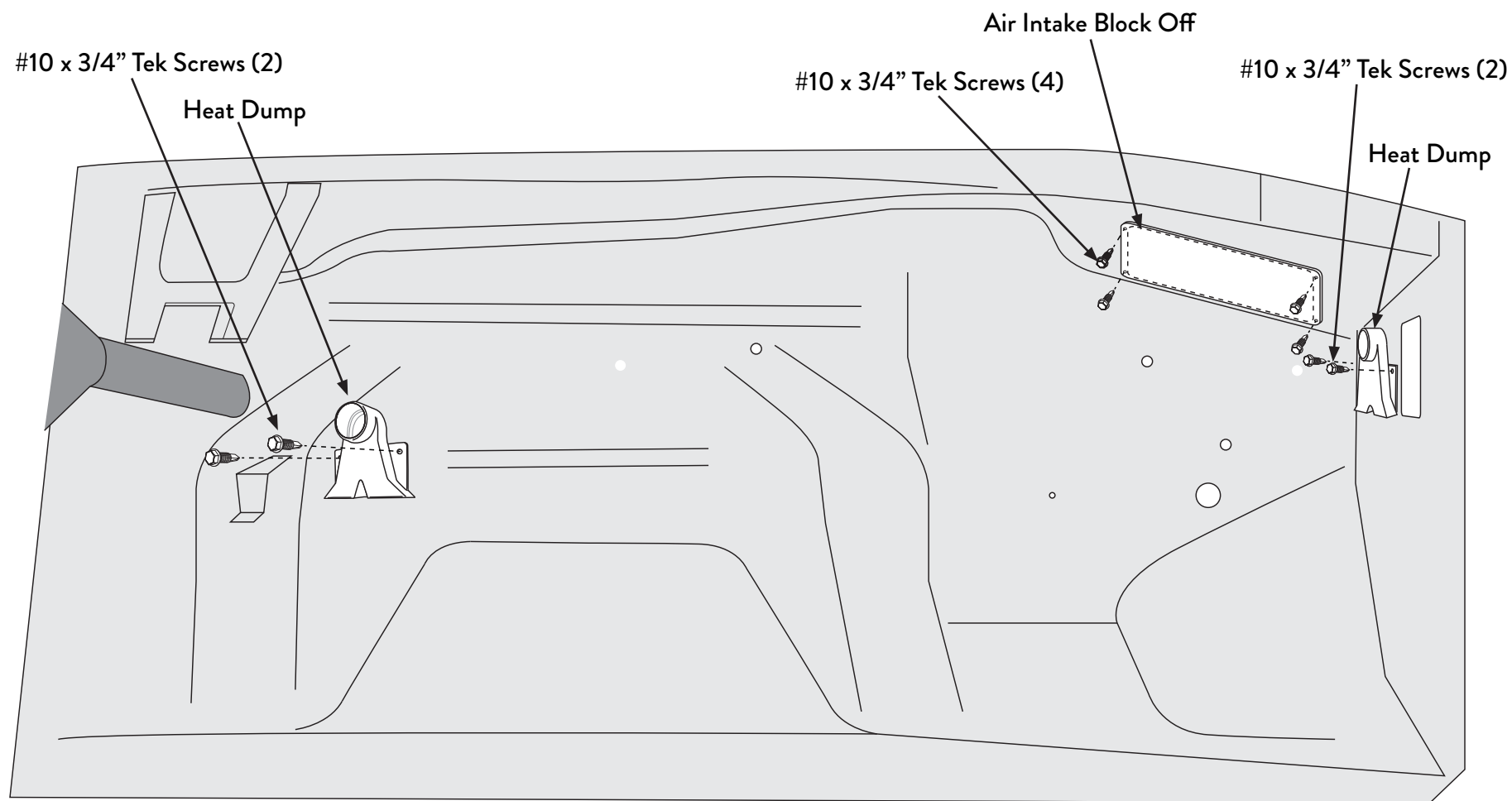

INTERIOR - FIREWALL

WIRING

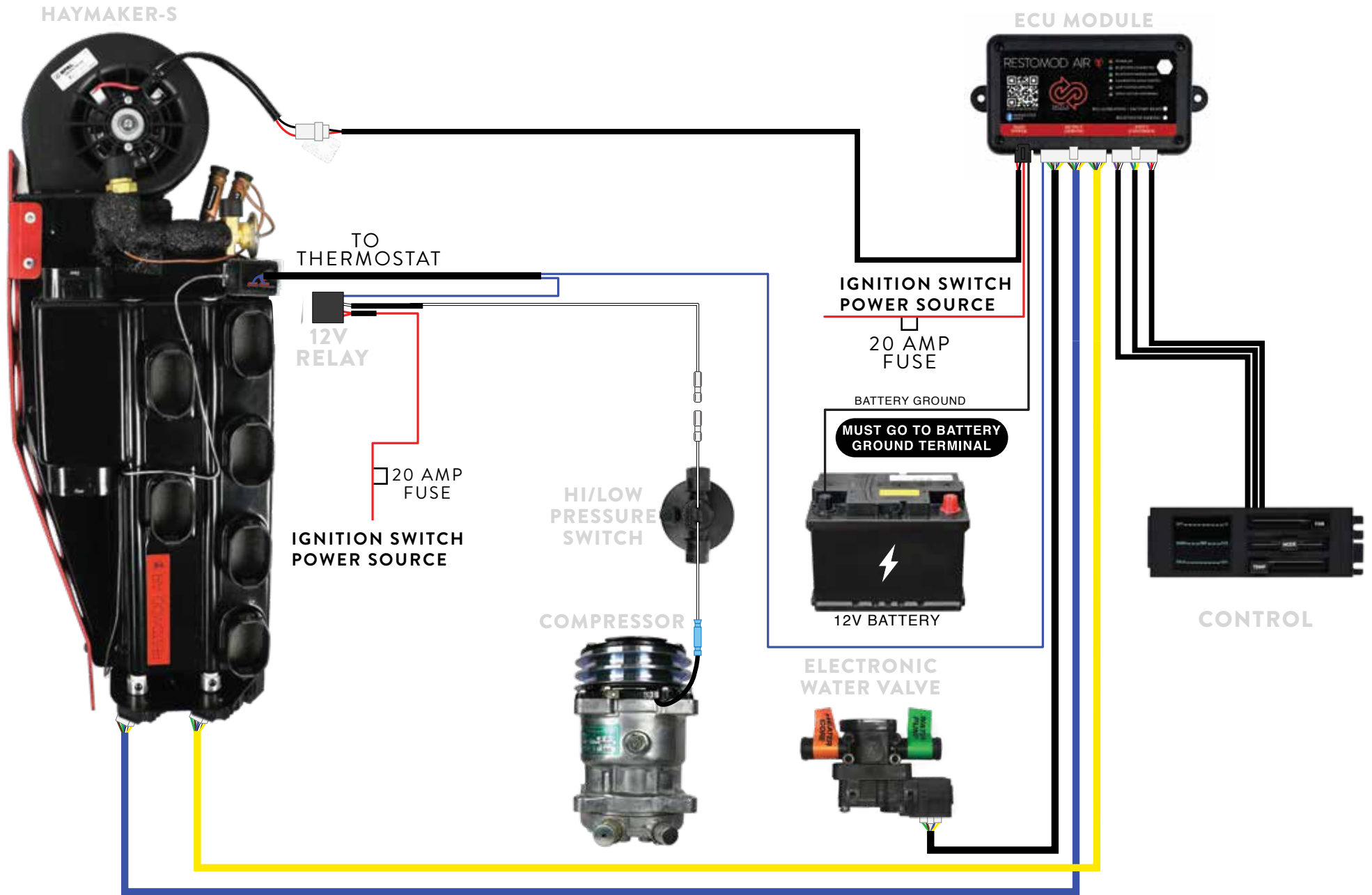

ECU OVERVIEW

SYSTEM STATUS

FLASH RED: Power On – Operation Mode

A flashing red LED means the system is powered on and should be functioning correctly.

FLASH BLUE: Bluetooth Connected

Flashing blue LED indicates that the system is receiving a Bluetooth signal. Your paired device should be capable of controlling your system's functions and providing current status updates along with diagnostic information.

FLASH GREEN: Bluetooth Pairing Mode

A flashing green LED indicates that the system is in pairing mode and ready to receive a Bluetooth signal. To pair a device, simply access your device's Bluetooth settings and select the system's name to establish the connection.

Note: The PIN no longer needs resetting with each use in this version. However, for security reasons, users can reset the PIN if needed, ensuring that only those with the chosen PIN can connect to their system.

SOLID WHITE: Calibration Mode Started

Solid white LED indicates that the system is calibrating. During calibration, each motor takes a turn moving through its full range of motion to calibrate the open and closed positions. Once calibration is complete, the LED should start flashing red.

BLUETOOTH PAIRING BUTTON:

The Bluetooth pairing button is used to pair your device to the ECU. Holding the button for 1 second should prompt the LED to start flashing green.



GEN 4

RM-ECU-0118-46

THE APP

Use your iOS or Android device to change your mode, temp, fan speed, check diagnostics and more. The Restomod Air app provides instantaneous wireless control and feedback of your a/c unit via Bluetooth. Available for free in the Apple App store or Google Play.

ADVANCED SYSTEM DIAGNOSTICS

Check how your a/c system is functioning in the diagnostics screen. You can see the voltage, current temperature and position of control and motor for your temperature, mode and fan speed.

SWITCH TECHNOLOGY

Switch Technology allows you to bounce back and forth between the app, hard control and remote control.

CUSTOMIZE

Change your dial theme, highlight color, upload a photo to your background and more.



Apple App store



Google Play

CONNECT BLUETOOTH

YOU MUST CHANGE FACTORY PIN TO ALLOW AUTO CONNECTION OF THE SWITCH APP TO RESTOMOD A/C SYSTEM.

- Launch the Restomod Air Switch App
- Hold the Bluetooth pairing button on ECU for 1 second
- (LED will flash GRN/RED if the mobile device has never connected to ECU)
- (LED flash ORG if the mobile device has previously connected to ECU)
- Select device to connect (RM_XXXX)
- Bluetooth Pairing request Enter Factory PIN (654321)
- Pair Device

TO CHANGE FACTORY PIN

- Settings > Change pin
- Enter Current Pin (654321)
- Enter NEW Pin (*****)
- System will disconnect
- Reconnect with new pin, now the Switch App will auto connect when system powers up.

CONTROLS

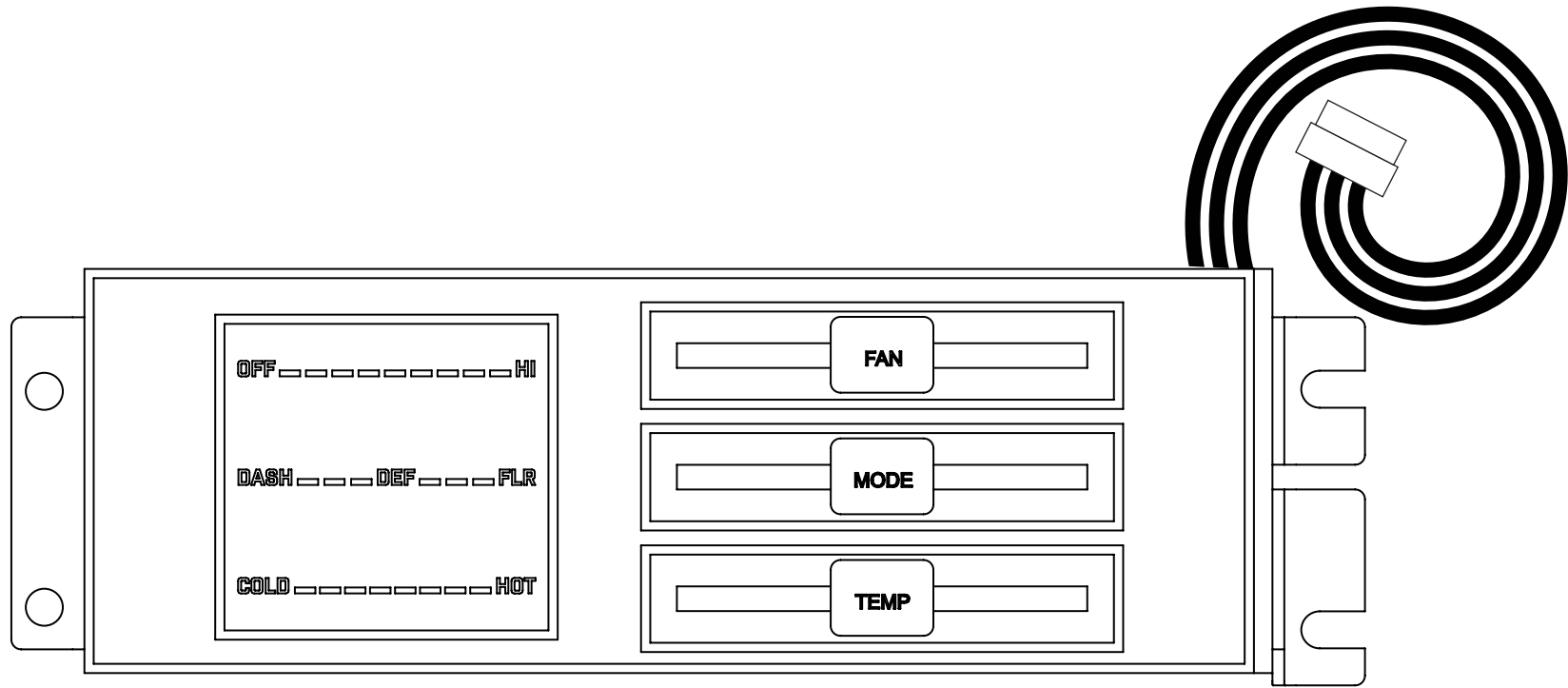

X-ACT Controller
Part# 16-4097

INSTALLATION - CONTROLS

Install new control box assembly into original dash location using original hardware.

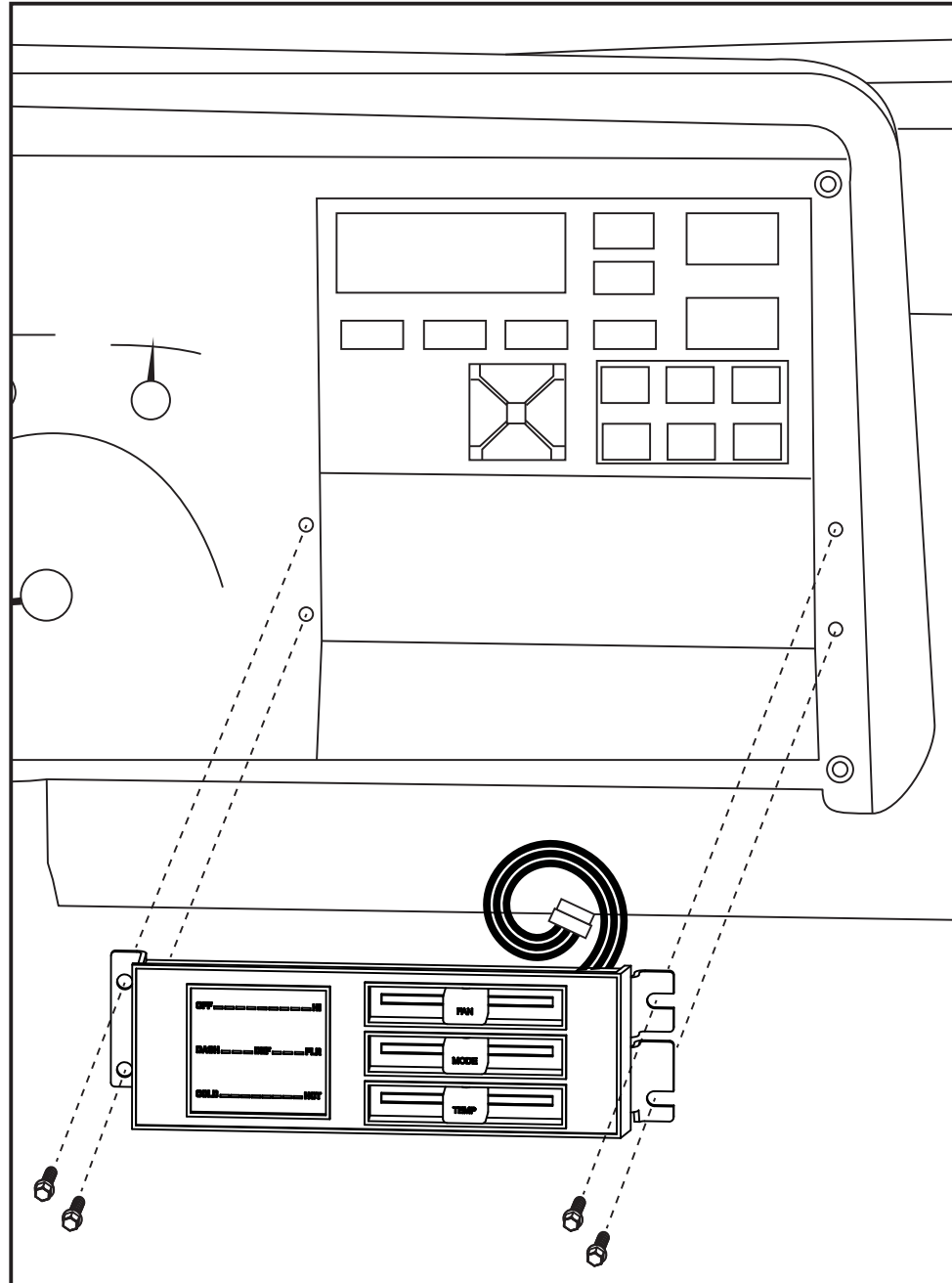

OPERATIONS

CONTROL & OPERATING INSTRUCTIONS

Your new Custom Fit A/C Kit offers complete comfort capabilities in virtually every driving condition. This includes temperature control in all of the modes. This system also provides the ability to blend the air between Face, Heat, and Defrost modes simultaneously. To illustrate the various ways you can adjust the airflow direction and temperature - we've provided these handy illustrations and chart to show exactly how you can adjust your Custom Fit A/C Kit for maximum comfort...

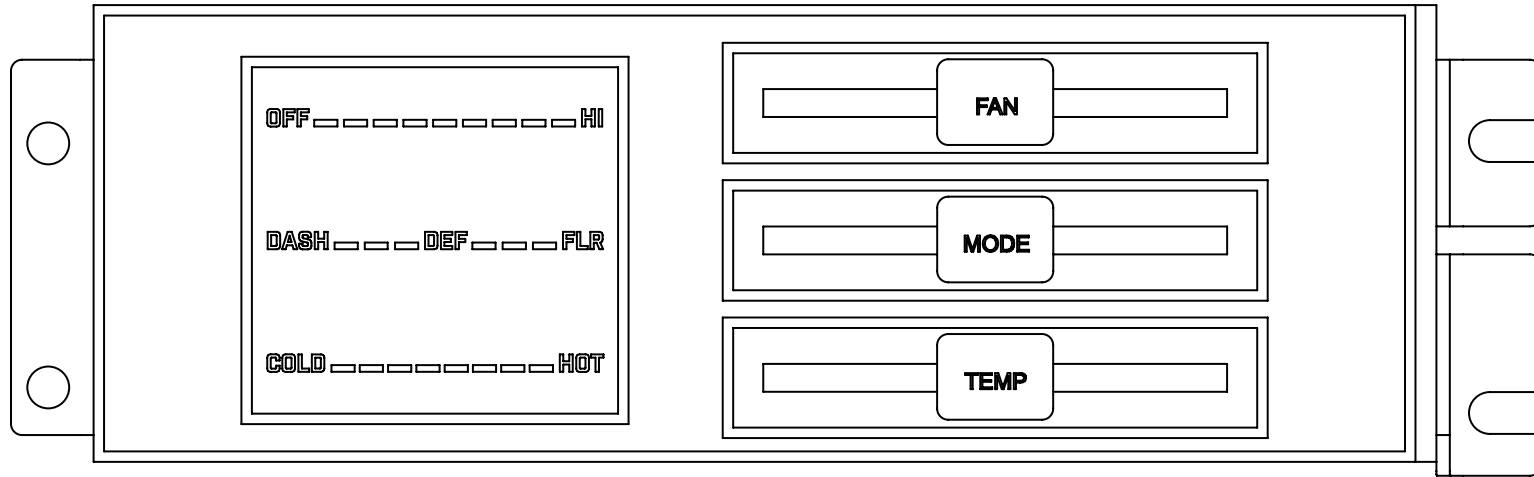

There are 11 levels of adjustment within the range of the DASH - DEF - FLOOR lever

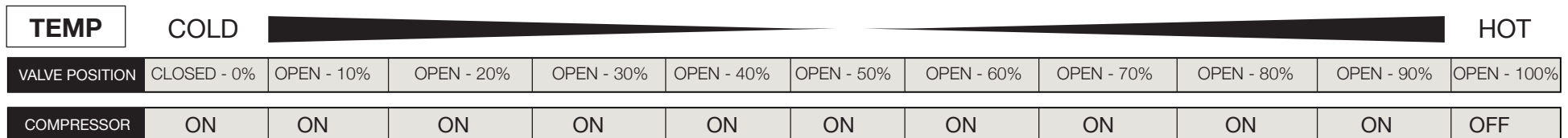
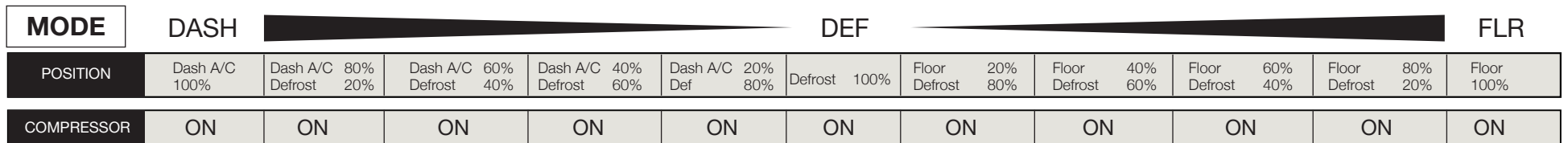

DEFROST + FLOOR DUCTS + VENTS

Use supplied zip ties to secure duct hose to defrost, floor ducts and vents. Cut duct hose to length needed. When cutting duct hose pull taut. Hose will stretch in summer months and possibly sag effecting the air flow.

TIP Make certain hose is not cut too loose where it is hanging. The smoother the routing of the flex hoses, the better the airflow.

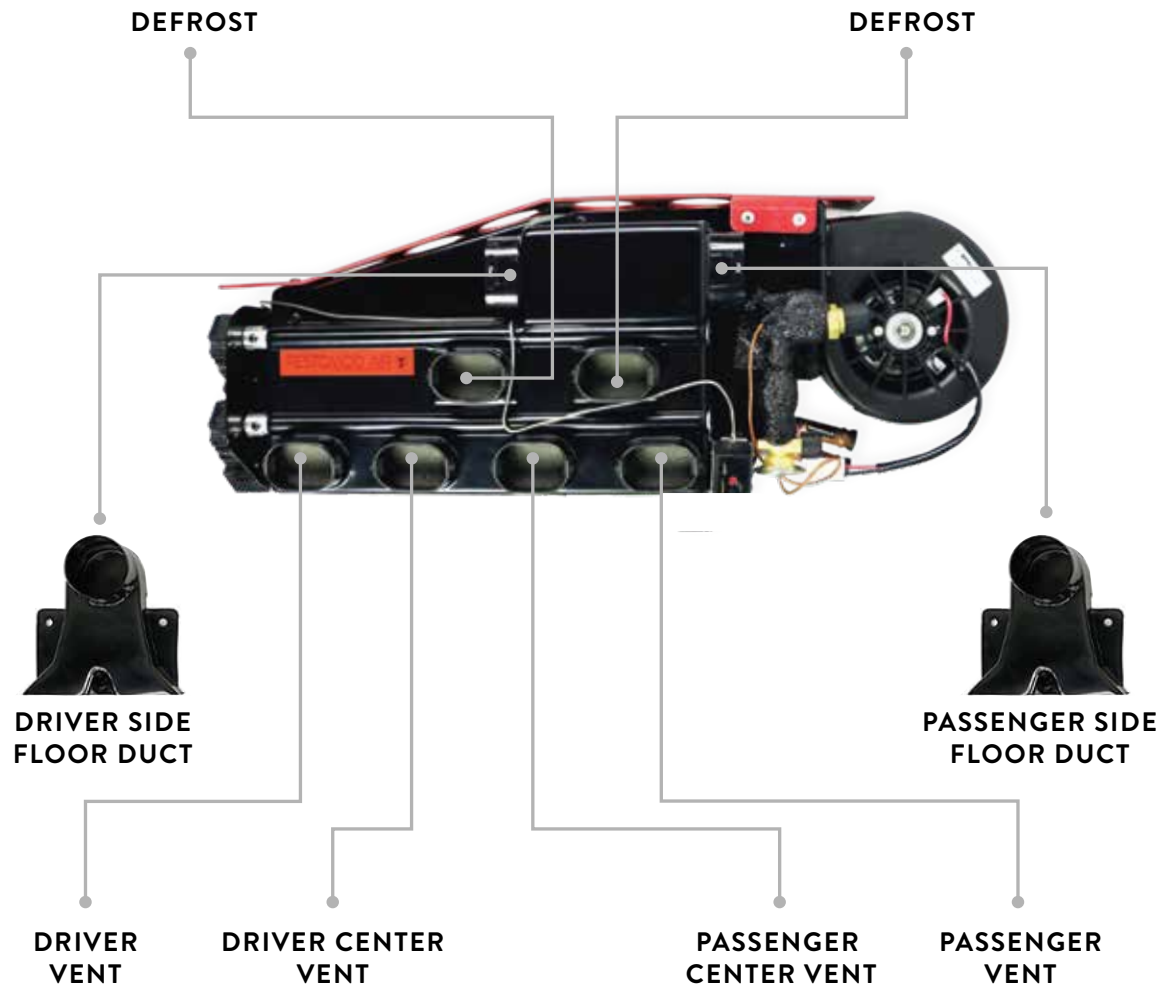

TIP

Work the duct hose on the adapter by squeezing the duct hose. Do not crush/pinch duct hose. Slight distortion is acceptable.

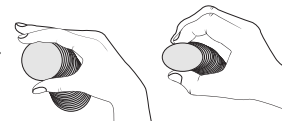

CENTER VENT PARTS

You will use all of these parts and hardware during the next series of installation steps.

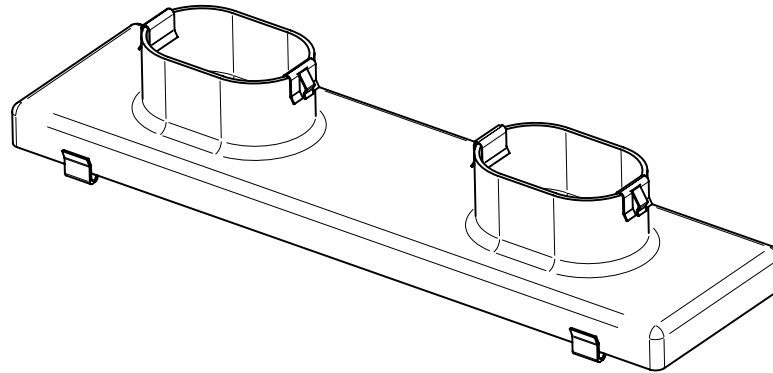

Hose Adapter Assembly, Center Vent
Part# 2-3097FA-4

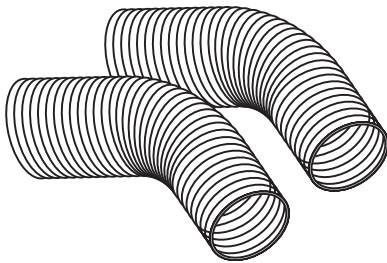

Duct Hose, 2" I.D., 2' L (Qty. 2)
Part# 2-1013

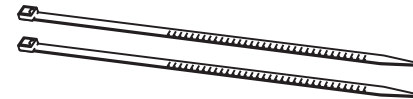

8" Zip-Tie (Qty. 2)
Part# AL-08-40-0-M

INSTALLATION - CENTER VENTS

Install center vent hose adapter onto center vent dash panel using attached S-clips. Attach and secure 2' duct hose to each adapter opening with provided zip ties. Reinstall center vent dash panel onto dash.

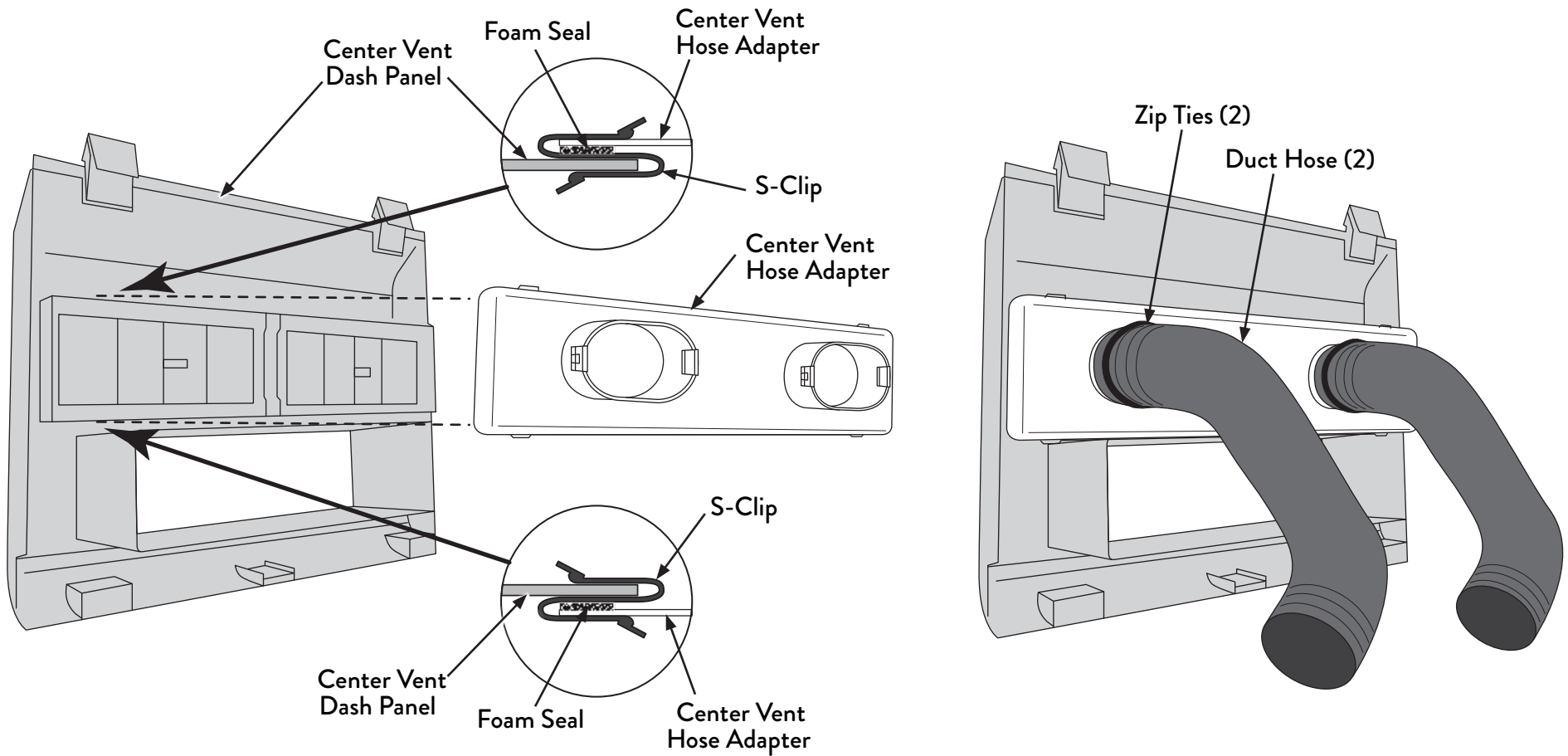

DRIVER & PASSENGER VENTS

You will use all of these parts and hardware during the next series of installation steps.

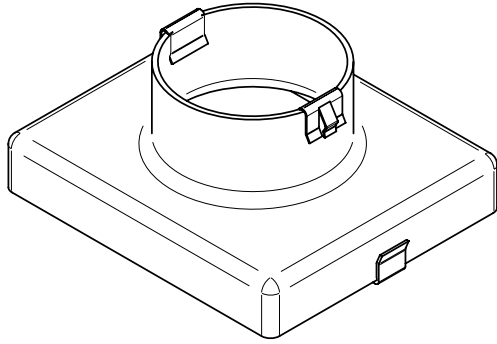

Hose Adapter Assembly, Driver Vent
Part# 2-3097FA-2

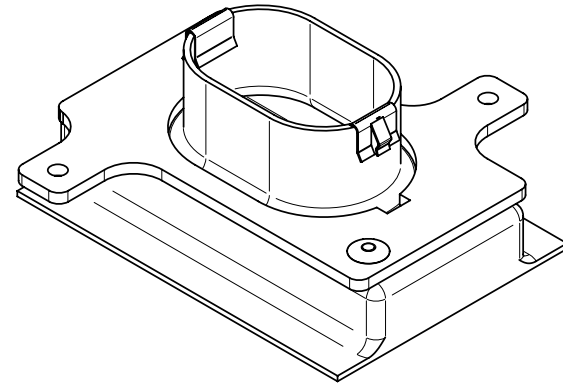

Hose Adapter Assembly, Passenger Vent
Part# 2-3097FA-3

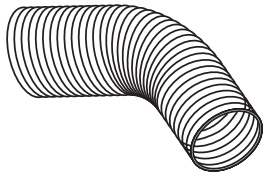

Duct Hose, 2" I.D., 2' L
Part# 2-1013

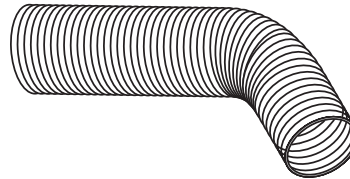

Duct Hose, 2" I.D., 4' L
Part# 2-1013



8" Zip-Tie (Qty. 2)
Part# AL-08-40-0-M

INSTALLATION - DRIVER & PASSENGER VENTS

Install driver side vent hose adapter onto gauge cluster trim panel as shown using attached S-clips. **NOTE: Be sure to clip the vent adapter to the housing of the vent and NOT on the vent itself or the vent will not move freely.** Attach and secure the 4' duct hose to adapter opening with provided zip tie. Reinstall gauge cluster trim panel onto dash.

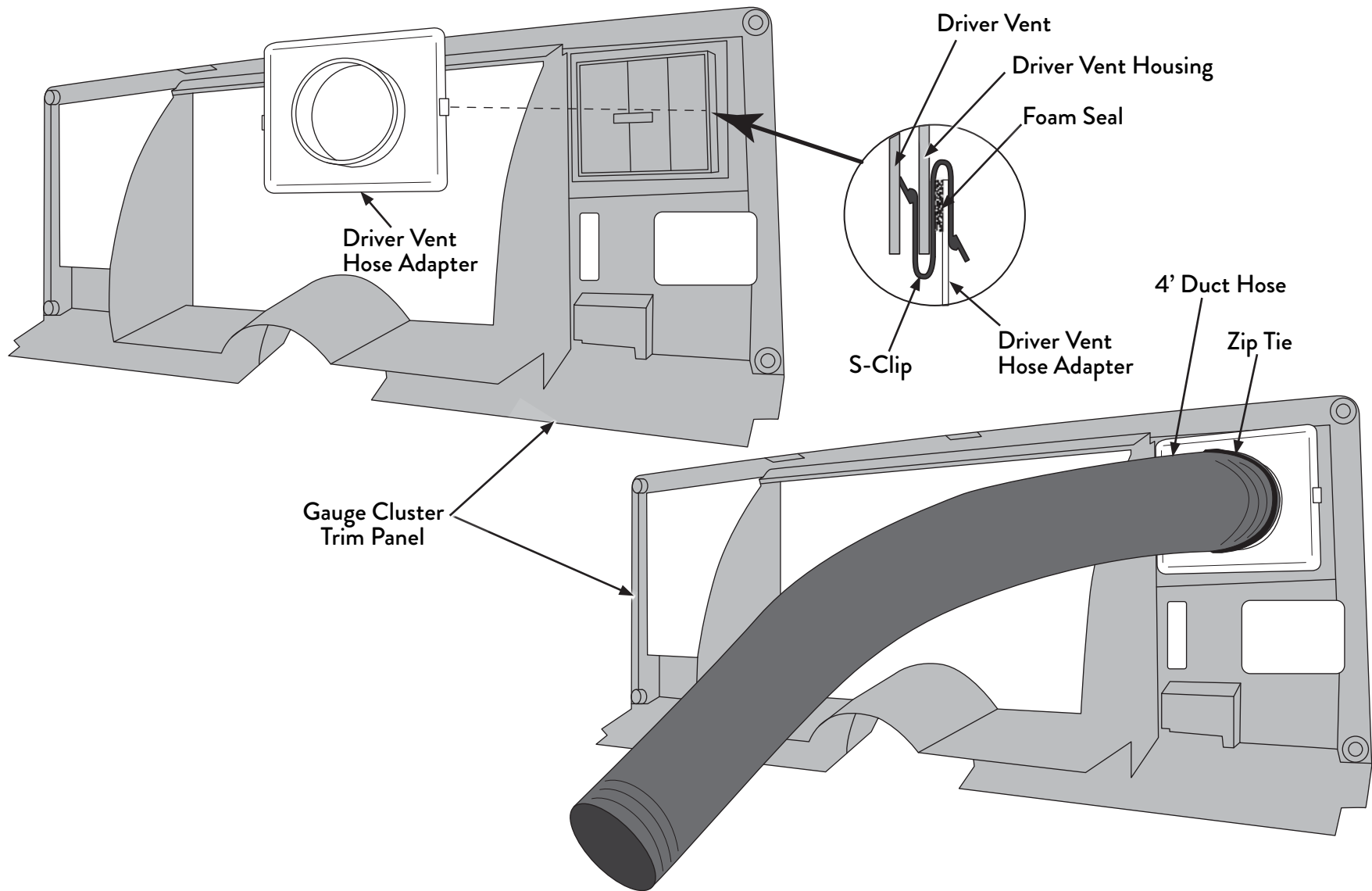

INSTALLATION - DRIVER & PASSENGER VENTS

Install passenger side vent hose adapter onto back of dash as shown using original factory hardware. Attach and secure the 2' duct hose to adapter opening with provided zip tie.

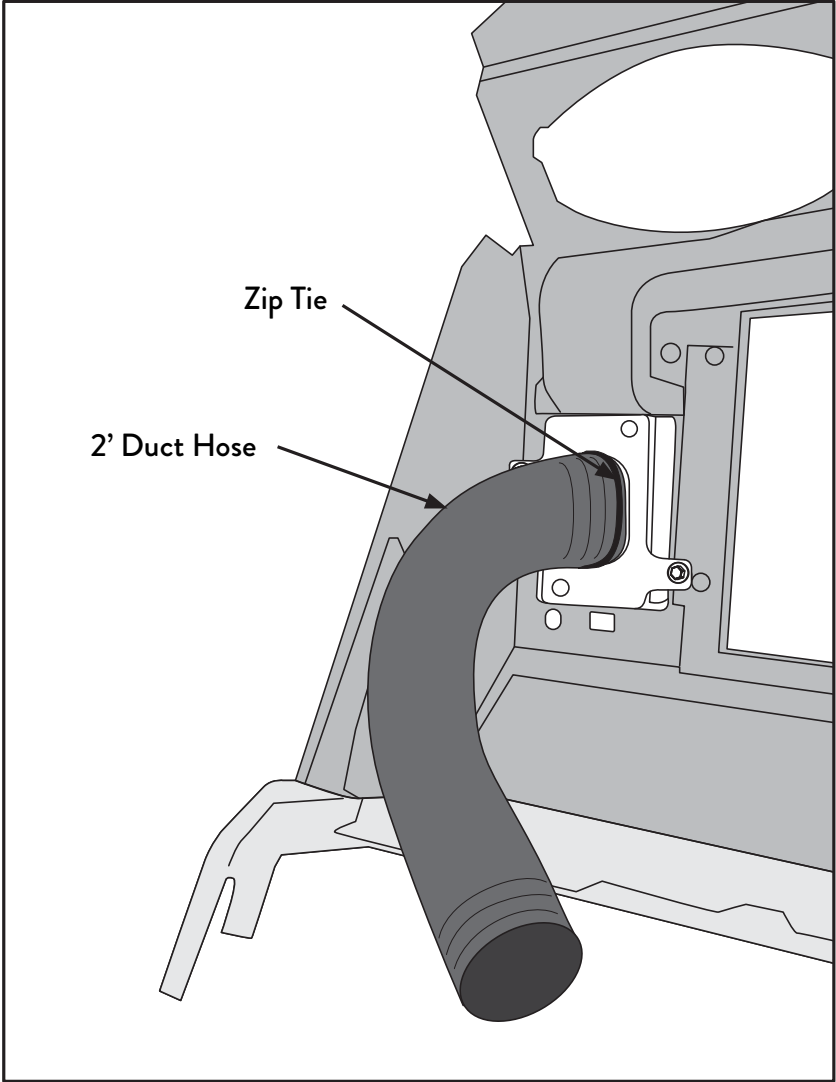
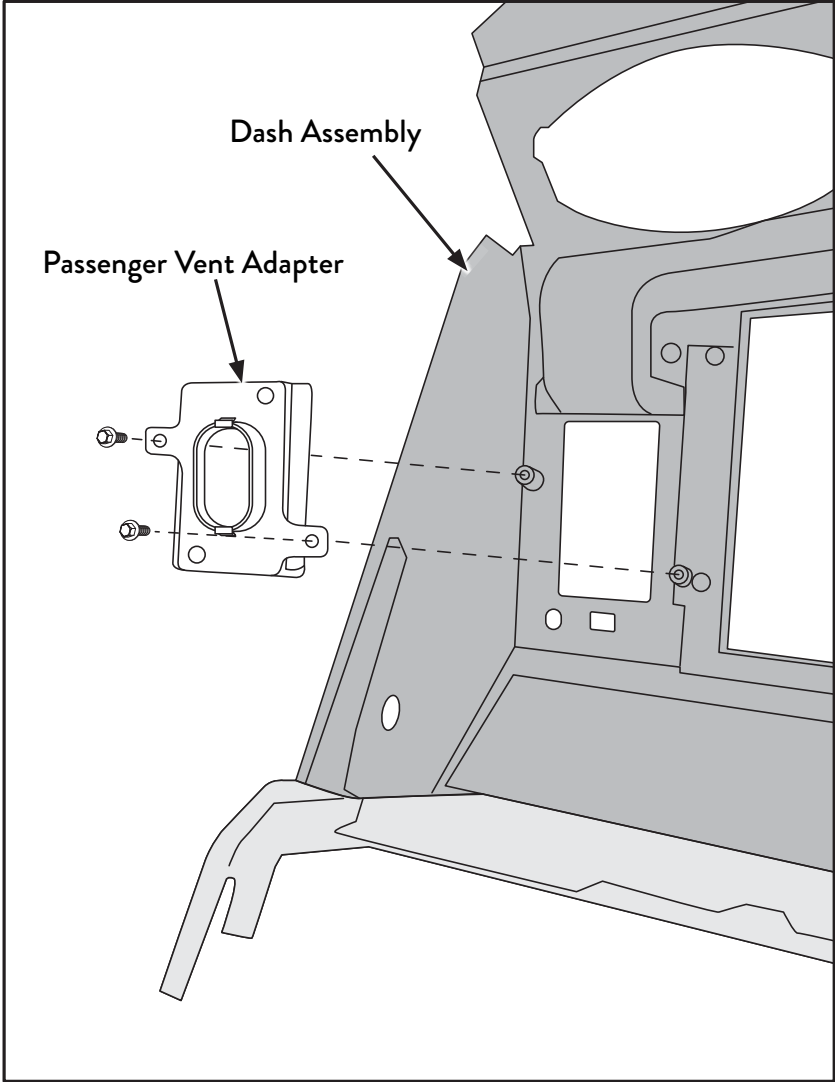

DEFROST VENTS

You will use all of these parts and hardware during the next series of installation steps.

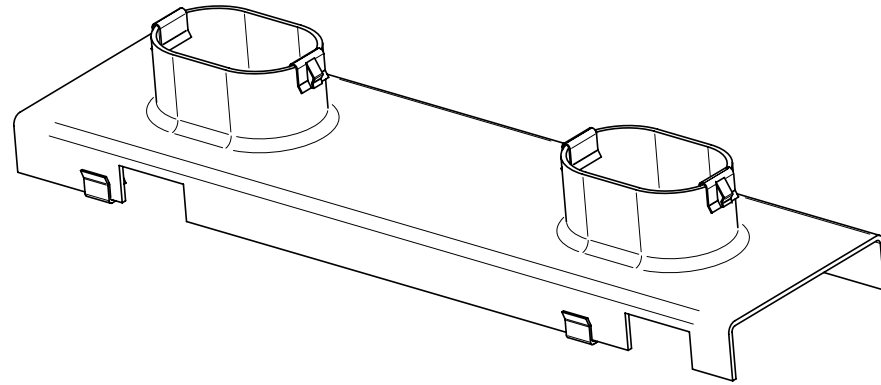

Hose Adapter Assembly, Defrost
Part# 2-3097FA-1

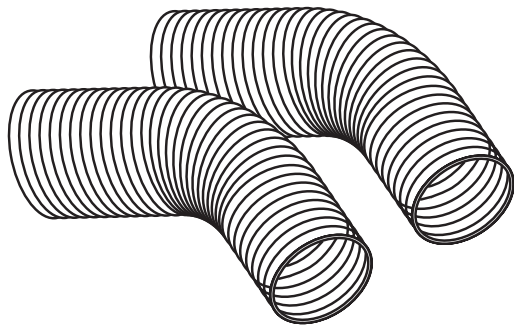

Duct Hose, 2" I.D., 2' L (Qty. 2)
Part# 2-1013

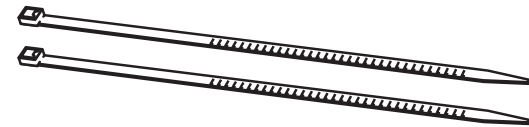

8" Zip-Tie (Qty. 2)
Part# AL-08-40-0-M

INSTALLATION - DEFROST VENTS

Install defrost hose adapter onto defrost duct as shown using attached S-clips. **NOTE: Be sure cut notches face bottom of adapter when installing.** Attach and secure 2' duct hose to each adapter opening with provided zip ties. Reinstall dash assembly into the vehicle.

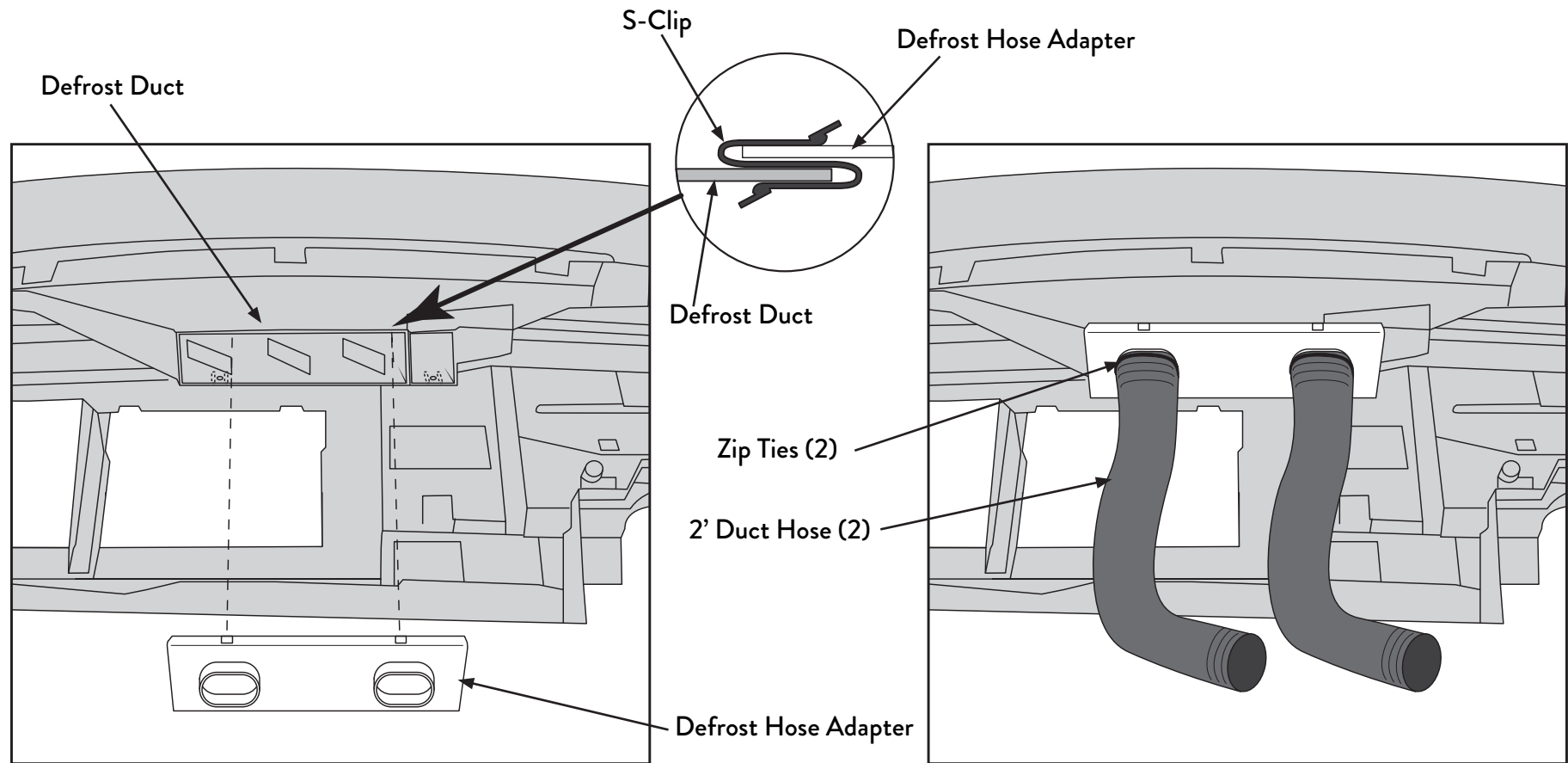

MODEL SPECIFIC CONDENSER KIT

(IF PURCHASED)

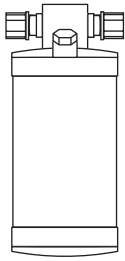

Drier
Part# 12-1008

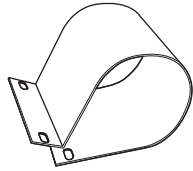

Drier Bracket
Part# 19-1003

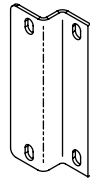

Drier Bracket Riser
Part# 0130-57

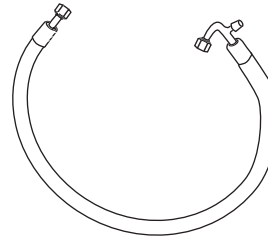

#10 (1/2") Refrigerant Hose, Suction
Part# 0132-92

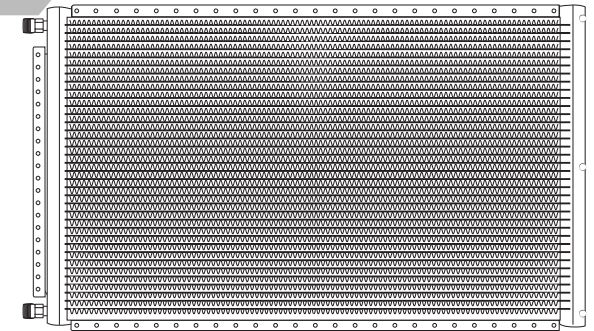

Condenser
Part# 11-1117

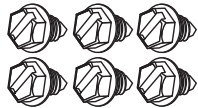

#10 (1/4") Hex Hd. Screw (Qty. 6)
Part# 10B25SHBZ

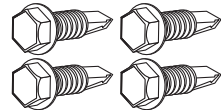

#10 (3/4") Tek Screw (Qty. 4)
Part# 10B75HW3Z



#8 (13/32") Refrigerant Hose, Discharge
Part# 0132-91

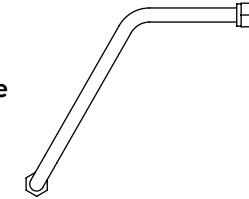

Tube, Discharge
Part# 0132-17

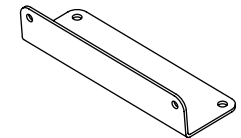

Lower Mounting Bracket, Condenser
Part# 0132-13



3/8" I.D. Grommet
Part# G1



1/2" I.D. Grommet
Part# G2

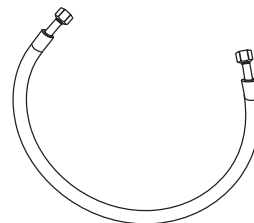

#6 (5/16") Refrigerant Hose, Liquid
Part# 0132-93



Tube, Liquid
Part# 0132-15R1

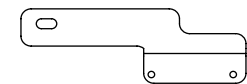

Upper Right Mounting Bracket, Condenser
Part# 0132-12



#8-32 x 1/2" Machine Screw (Qty. 4)
Part# 18C50PPHZ

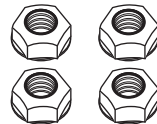

#10-32 Nyloc Nut (Qty. 4)
Part# 10FNNEZ

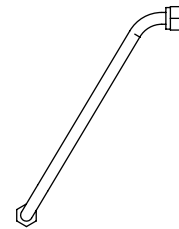

Tube, Liquid
Part# 0132-16

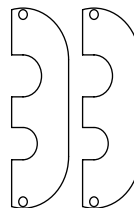

Tube Clamp Bracket
Part# 0132-14 (Qty. 2)

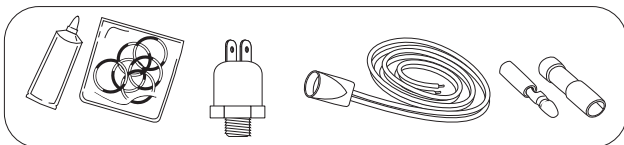

Hi/Low Pressure Switch Kit
Part# 16-1007

INSTALLATION - CONDENSER PREP

Remove original grill, hood latch and condenser. Retain all original hardware. Place the condenser on a clean, flat surface and orient it so both tube fittings are facing to the right and the larger #8 fitting is at the top. Locate and install the bottom mounting bracket to the bottom center of the condenser (there should be 10 empty holes on either side of the bracket) and secure with (2) #10-20 x 1/4" Hex Head Screws as shown.

NOTE: Make sure the bracket's shorter flange is attached to the condenser and the longer flange is going under the condenser as shown. Also, make sure to use the #10 x 1/4" Hex Head Screws and NOT the Tek Screws.

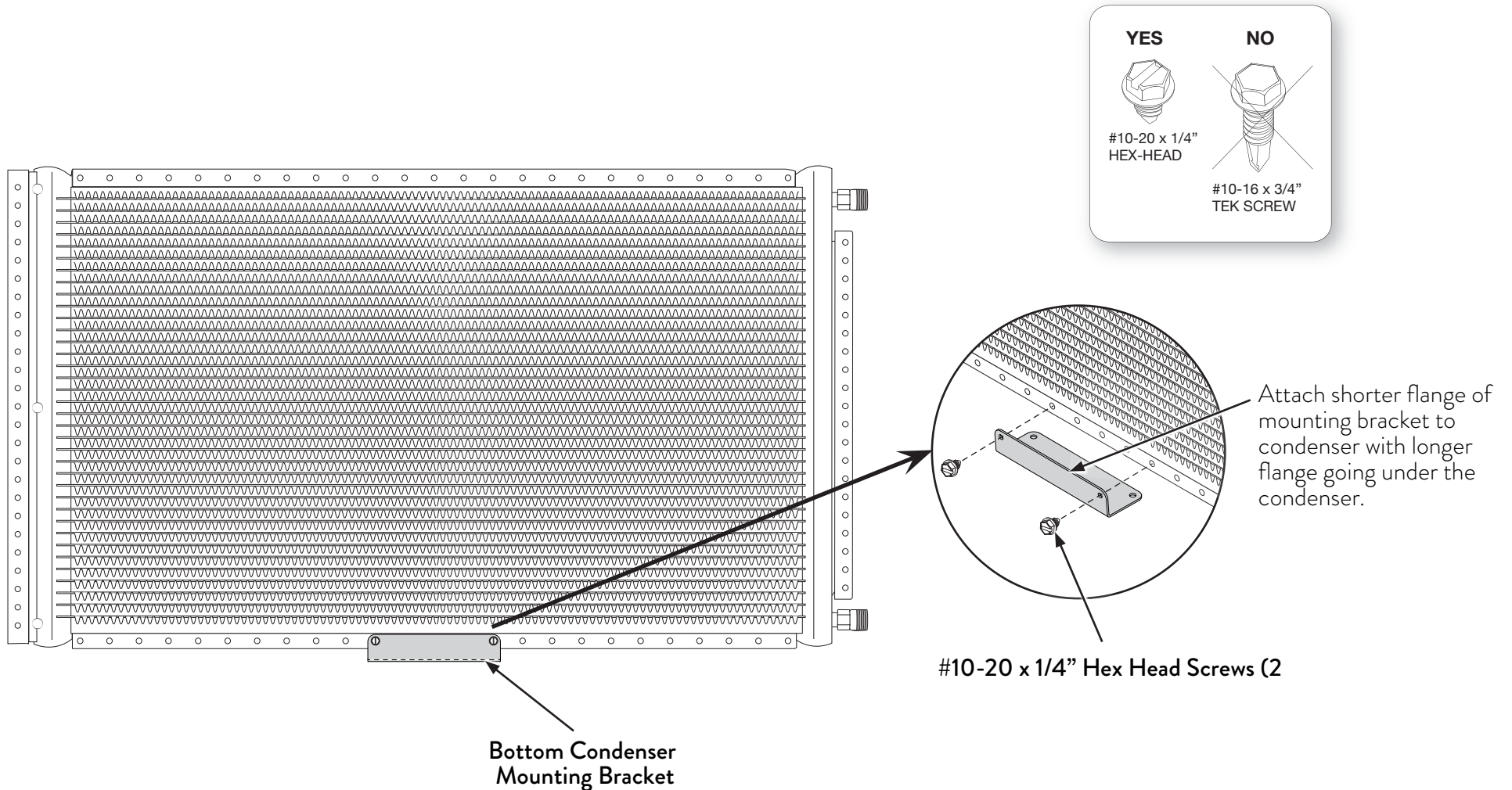

INSTALLATION - CONDENSER PREP

Turn the condenser over so the tube fittings are facing toward the right and the larger #8 is at the top. Locate and install the top left mounting bracket to the condenser using the left side top row holes and secure the bracket with (2) #10-20 x 1/4" Hex Head Screws as shown.

NOTE: Make sure the bracket is oriented as shown. Also, make sure to use the #10 x 1/4" Hex Head Screws and NOT the Tek Screws.

Locate and install the top right mounting bracket to the condenser using the right side top row holes and secure the bracket with (2) #10-20 x 1/4" Hex Head Screws as shown.

NOTE: Make sure the bracket is oriented as shown. Also, make sure to use the #10 x 1/4" Hex Head Screws and NOT the Tek Screws.

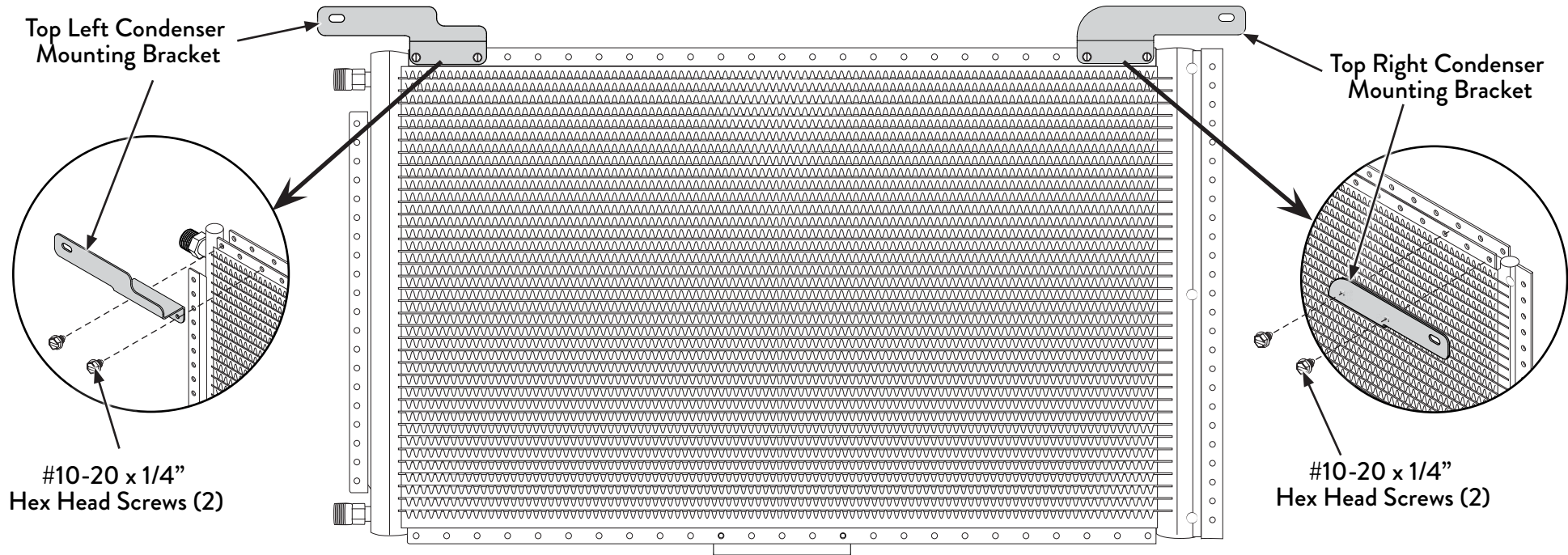
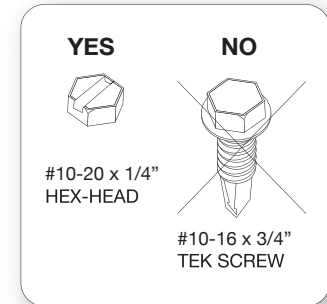

INSTALLATION -DRIER

Install the drier bracket around the drier.

Locate and attach drier riser bracket to the drier bracket as shown using (2) #8-32 x 1/2" machine screws and (2) #8 Nyloc nuts. Make sure the bracket is oriented as shown so the rounded corner flange is attached behind the drier bracket and the second flange is going away from the drier bracket.

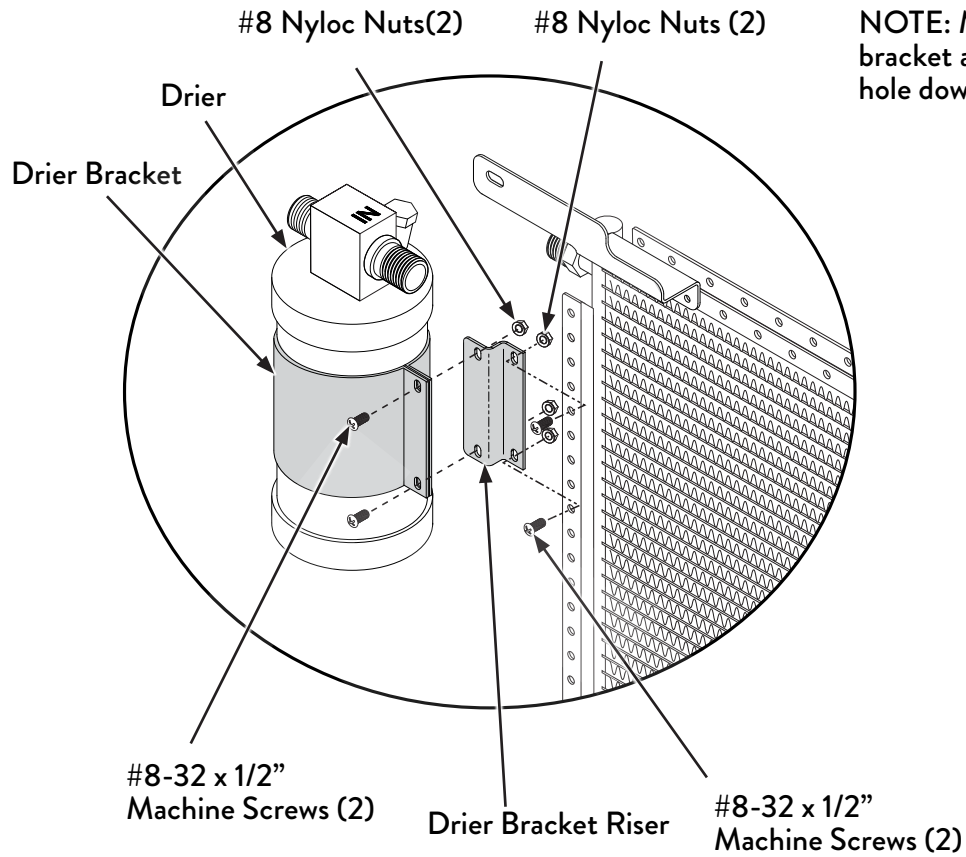

NOTE: Mount drier bracket assembly to 5th hole down on condenser.

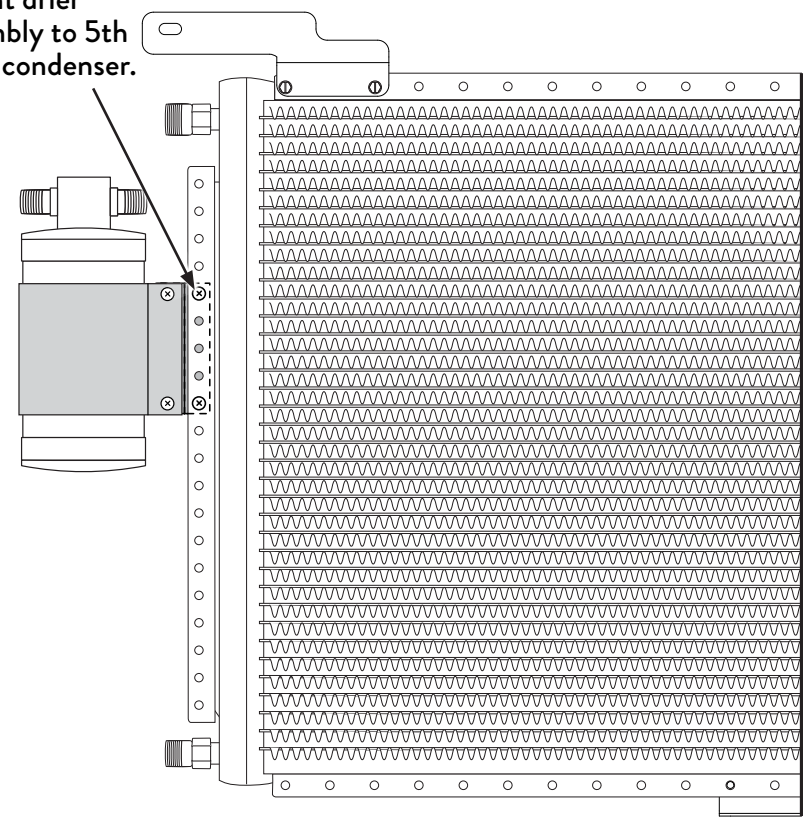

INSTALLATION - LIQUID TUBE

Install #6 liquid tube from the lower #6 liquid connection on the condenser to the inlet port on the drier as shown with a #6 O-ring and a few drops of mineral oil.

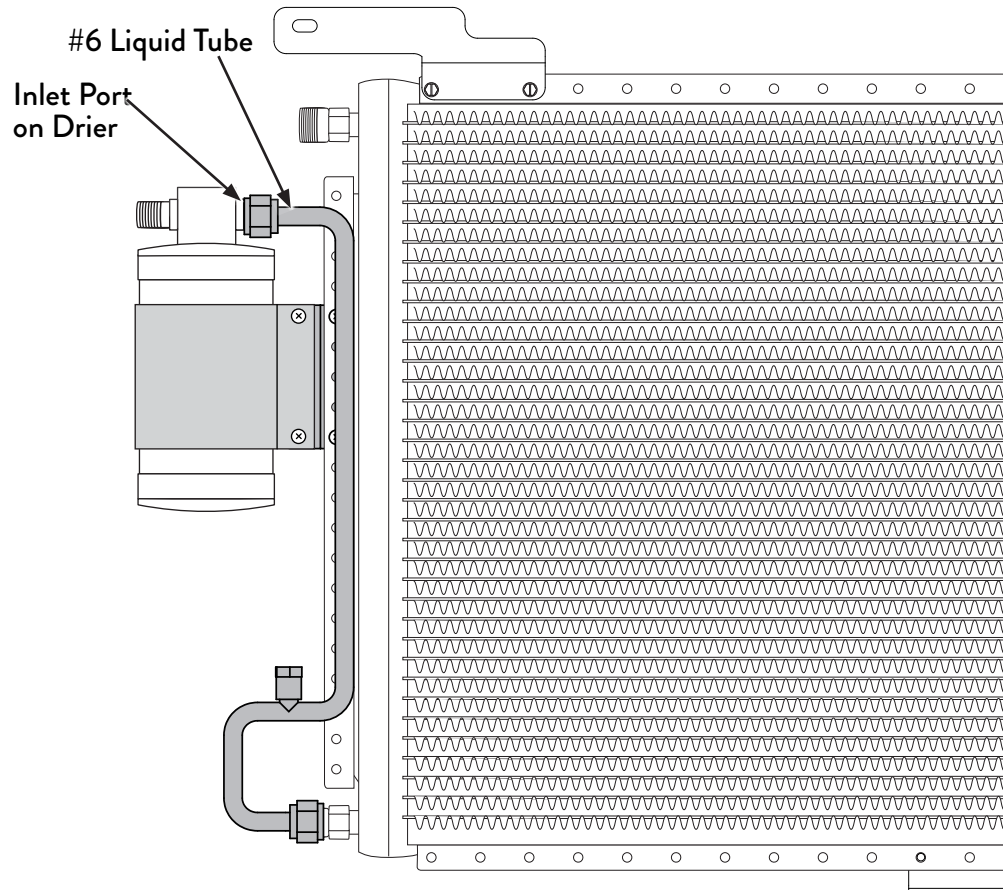

IMPORTANT

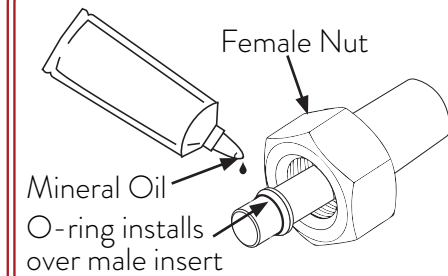

NOTE: For a proper seal of fittings, install the O-rings as shown with supplied mineral oil. Tighten fittings using two wrenches.

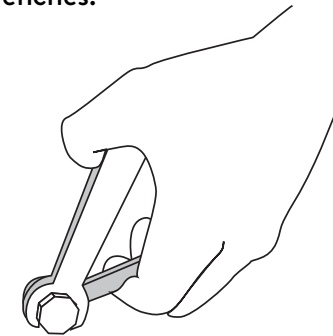

INSTALLATION - CONDENSER

Install the condenser assembly into the radiator support bulkhead, oriented so the fittings face the passenger side.
Secure using the original hardware.
Secure the bottom mounting bracket of the condenser to the radiator support bulkhead using (2) #10 x 3/4" Tek screws.

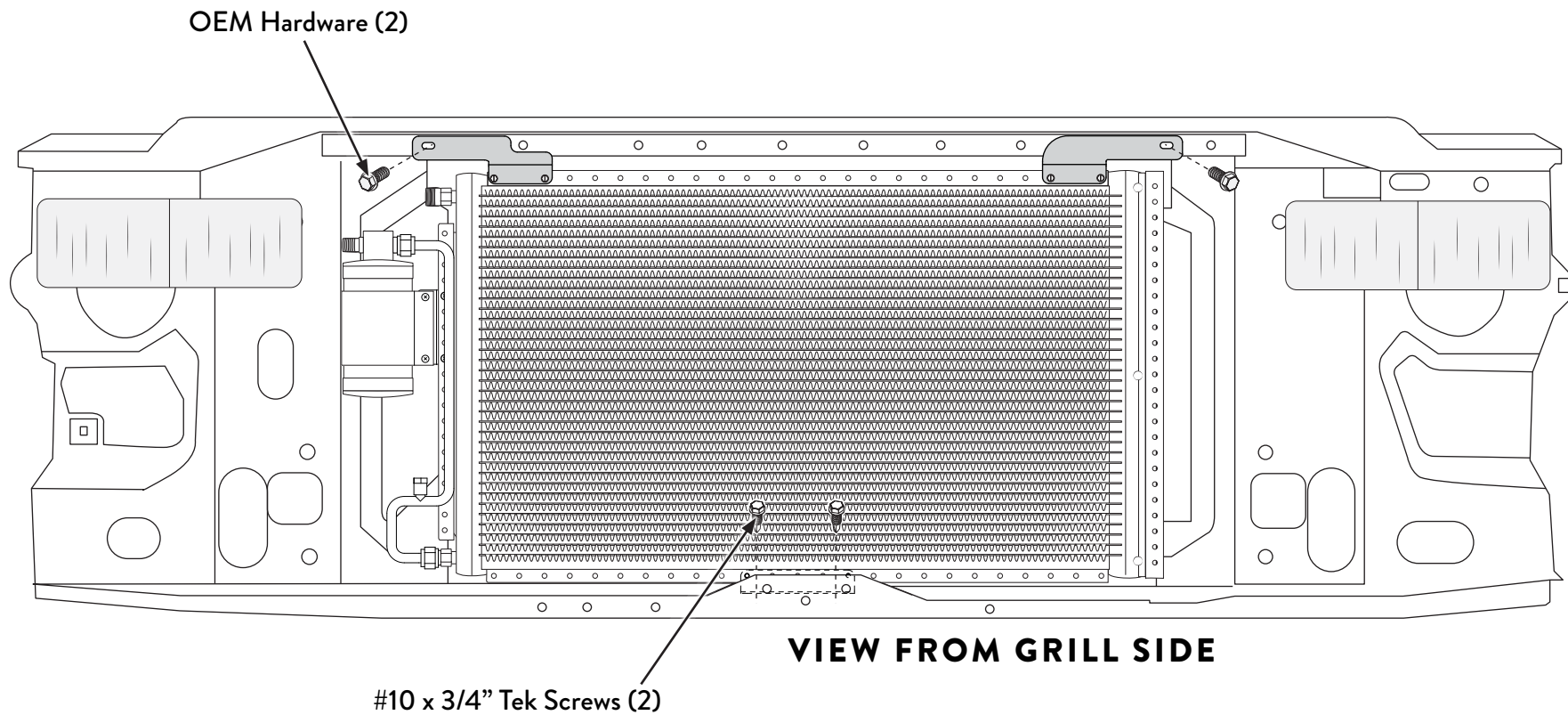

INSTALLATION - LIQUID & DISCHARGE TUBE

Install the #8 discharge tube into the opening in the radiator support and place behind the headlight and attach end to discharge connection on condenser as shown using #8 O-ring and a few drops of mineral oil.

Install the #6 liquid tube into the opening in the radiator support and attach end to outlet port on the drier as shown using #6 O-ring and a few drops of mineral oil.

Slice the 3/8" I.D. grommet and install onto the liquid tube at the radiator support opening.

Slice the 1/2" I.D. grommet and install onto the discharge tube at the radiator support opening. Slide (2) tube clamp brackets into grommet grooves as shown and secure to the radiator support using (2) #10 x 3/4" Tek screws.

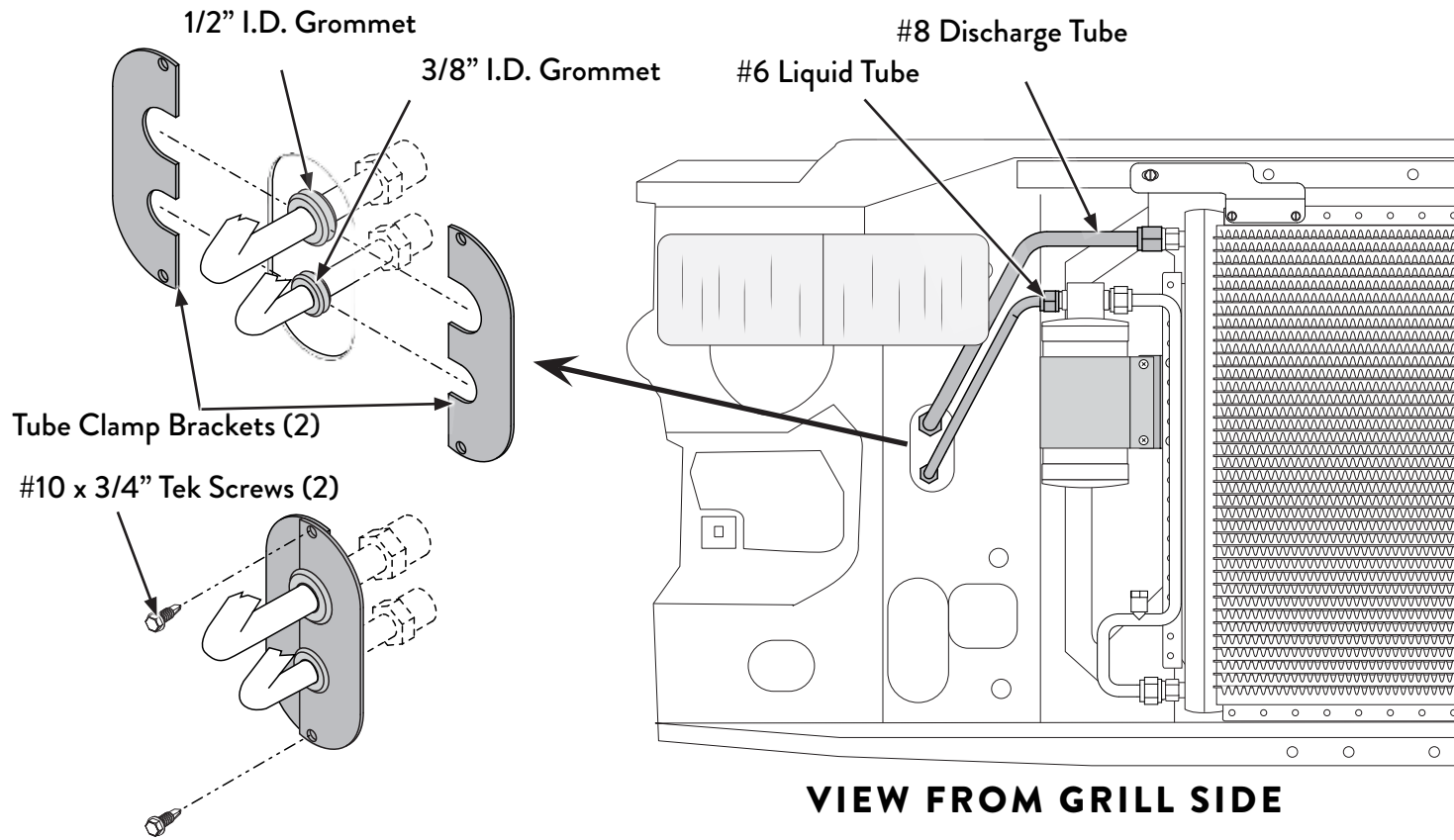

IMPORTANT

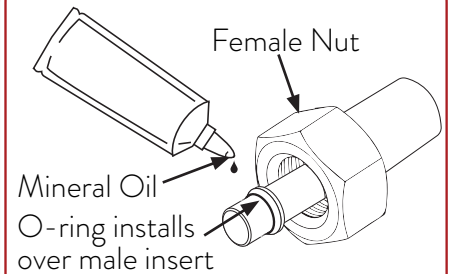

NOTE: For a proper seal of fittings, install the O-rings as shown with supplied mineral oil. Tighten fittings using two wrenches.

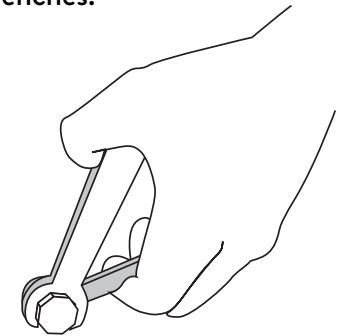

INSTALLATION - REFRIGERANT HOSES

Attach the #6 (5/16") liquid hose straight end to the #6 liquid tube with a #6 O-ring and a few drops of mineral oil.
Attach the other end of the #6(5/16") liquid hose to the liquid hose connection from the evaporator at the firewall with a #6 O-ring and a few drops of mineral oil.
Attach the #8 (13/32") discharge hose straight end to the #8 discharge tube with a #8 O-ring and a few drops of mineral oil.
Attach the other end of the #8 (13/32") discharge hose (with service port) to the compressor with a #8 O-ring and a few drops of mineral oil.
Attach the #10 (1/2") suction hose 135 degree end with the service port to the compressor with a #10 O-ring and a few drops of mineral oil.
Attach the #10 (1/2") suction hose straight end to the suction tube connection from the evaporator to the firewall with a #10 O-ring and a few drops of mineral oil.

IMPORTANT

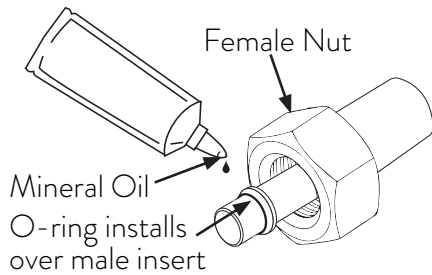

NOTE: For a proper seal of fittings, install the O-rings as shown with supplied mineral oil. Tighten fittings using two wrenches.

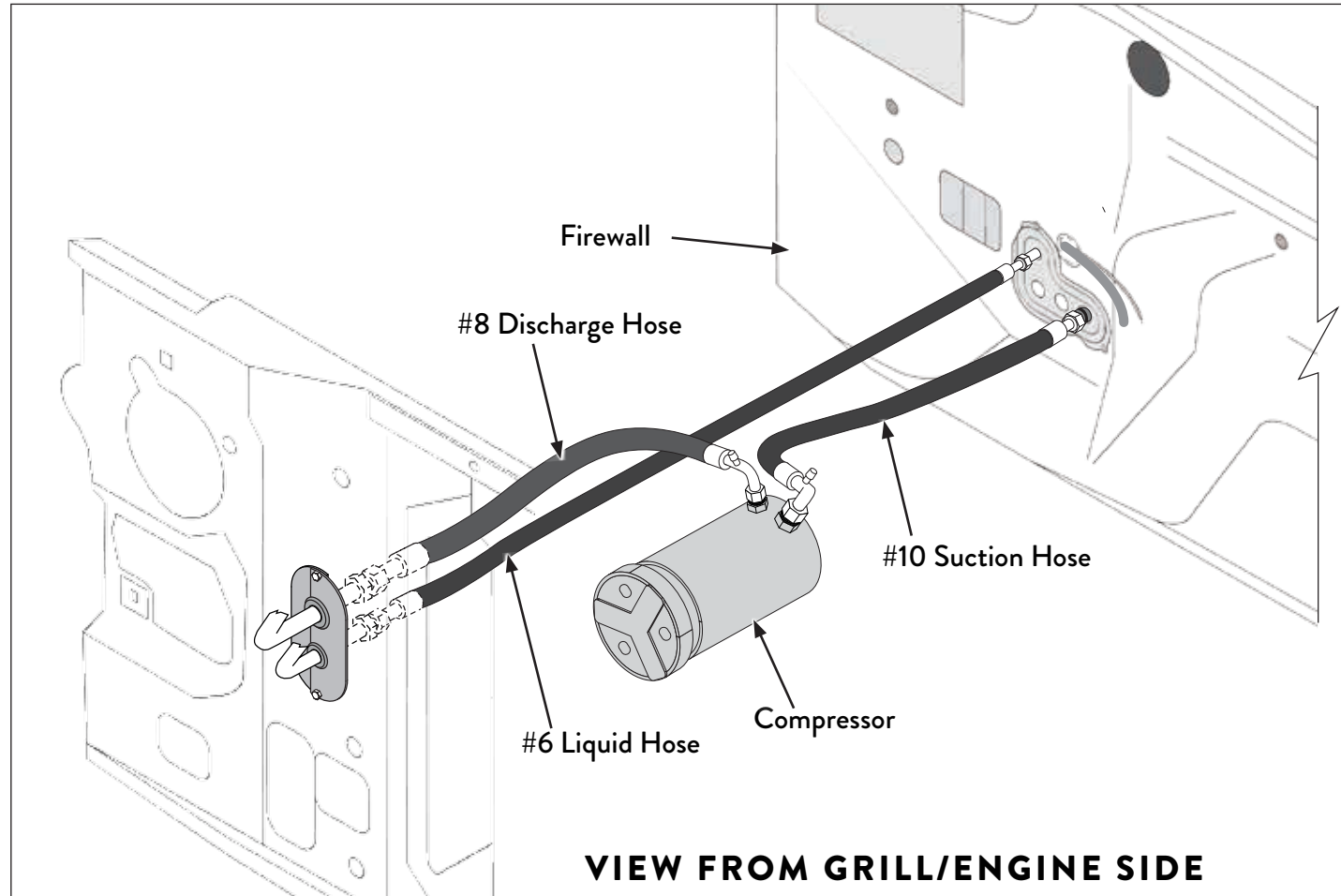
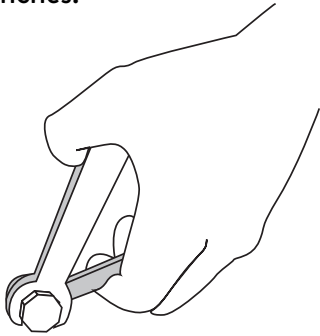

CUSTOM FIT CONDENSER KIT

(IF PURCHASED)

CONDENSER BRACKETS

Use provided brackets or fab your own from mounting points.
Secure condenser to minimize movement.

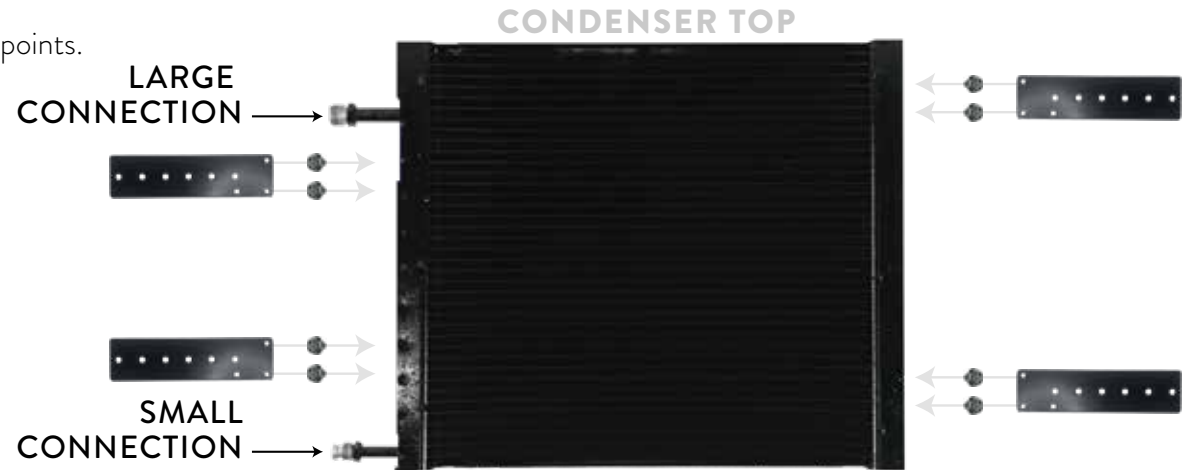

CONDENSER MOUNTING

Place condenser in front of radiator within 1". Mount to radiator support with self tapping screws. Some condensers have mounting points on the top.



O-RINGS

When installing o-rings on the hose connections, be certain the o-ring is properly sealed. Also check for sharp edges on the seat. If installed wrong, or the seat has a sharp burr, the o-ring can be cut.

TIP Use the o-ring pack supplied. Not all sizes and quantities will be used.

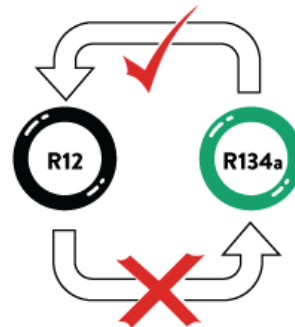

IMPORTANT

• Make sure you seal all holes/seams or anything else that will allow engine or outside air to enter the cabin. Failing to do so will prevent a/c unit to perform at it's highest ability.



• Use 2 wrenches to tighten fittings. Do not over tighten. Use a few drops of mineral oil with every o-ring.

LOCATION OF THE CONDENSER

Since this is a custom installation, many of our procedures can be viewed as suggestions. Your personal preferences will play a major role in the actual installation.

Condenser is purchased separate. Make sure you have the largest possible size condenser for your vehicle. Surface area is important for maximum cooling. Rule of thumb is condenser size matches the “finned” area of the radiator.

- condenser needs to be mounted in a location where hoses can reach
- should be within 1” from radiator without touching
- condenser has 2 fitting connection: larger #8 connection on top, smaller #6 on bottom.

Fab condenser mounting brackets to minimize condenser movement. Condenser can be mounted w/fitting connections on passenger or driver side.

TIP Failure to mount condenser with large fitting on top will result in system functioning incorrectly.

You can not lay down condenser flat/parallel to the ground. The oil within the system is heavier & thicker than refrigerant gas. The gas separates leaving the oil trapped in the condenser, ultimately starving the compressor of lubrication.

LOCATION OF DRIER

- drier needs to be mounted in a location where hoses can reach. Keep in mind refrigerant hoses from condenser & evaporator must connect to it.
- drier mounts vertical with connections on top. Threaded connection labeled “IN” will connect to the lower connection of the condenser.
- do not leave drier open longer than a couple minutes. Doing so will require the drier to be replaced.
- the drier has a location for the pressure switch/trinary switch to thread into.

Receiver/driers are located in the high-pressure section of the system, usually in the plumbing between the condenser outlet & the expansion valve inlet, although some may be connected directly to the condenser.

They serve 3 very important functions:

1. They act as a temporary storage container for oil & refrigerant when neither are needed for system operation (such as during periods of low cooling demand). This is the “receiver” function of the receiver/drier.
2. They trap very small debris that may be inside the a/c system.
3. They contain desiccant. The desiccant is used to absorb moisture that may have gotten inside the a/c system during manufacture, assembly or service. Moisture can get into the a/c components from humidity in the air. This is the “drier” function of the receiver/drier.

The receiver/drier should be replaced any time the system is opened for service, and most compressor warranties require it. The desiccant is only capable of absorbing a certain amount of moisture, and when the inside of the system and/or the receiver/drier are exposed to the atmosphere, the desiccant can become very quickly saturated from humidity in the air. If this occurs, the desiccant is no longer effective, and will not provide future protection. Additionally, the filter inside the receiver/drier could be restricted by debris that may have been inside the system. This could diminish refrigerant and oil flow.

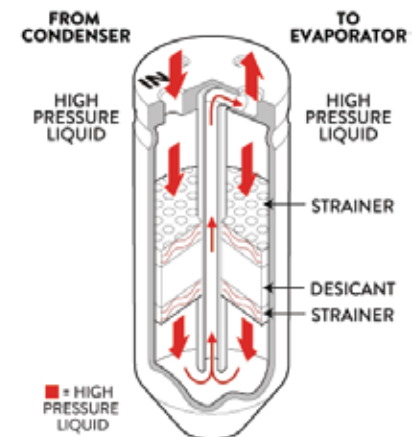
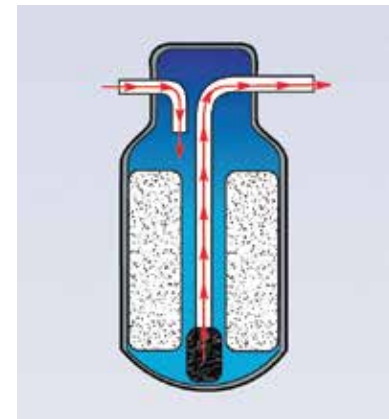

LOCATION OF COMPRESSOR & HOSES

LOCATION OF COMPRESSOR

Use installation instructions provided by your engine bracket manufacturer.

- TIP** Most brackets mount compressors either passenger or driver side.
- TIP** Compressor fittings **cannot** be mounted with fittings downward

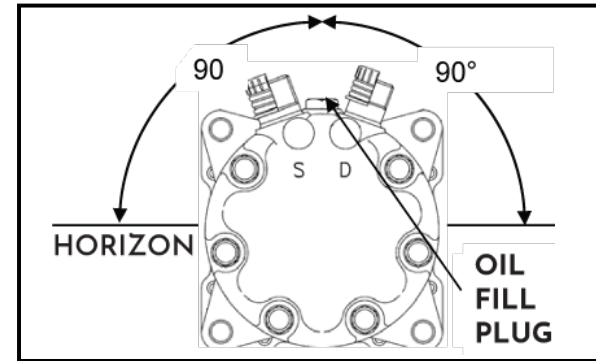

LOCATION OF HOSES

- make certain hoses have enough slack when connecting to compressor so that fittings do not prematurely fatigue w/engine vibrations
- make certain hoses are secured with supplied clamps so hoses don't rub against objects
- hose fittings must be crimped by a reputable service center or can be sent back to us.
- hydraulic crimping cannot be used, automotive a/c crimping dies are only suitable for refrigerant barrier hoses.

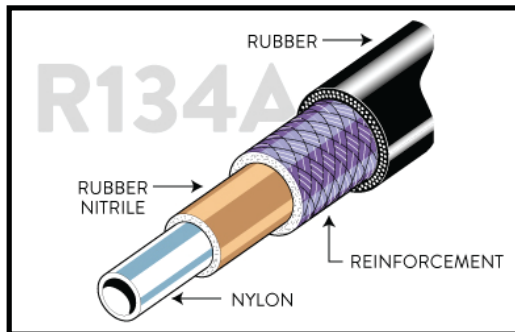
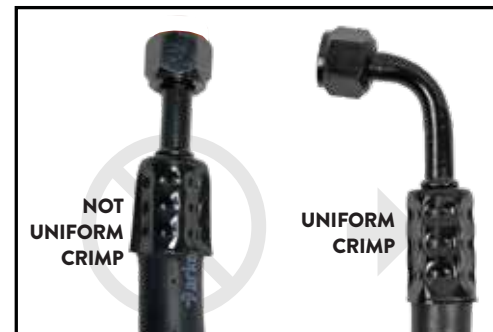

HOSE REFERENCE

SIZE	HOSE
5/16"	#6 Liquid Hose
5/8"	Heater Hose
13/32"	#8 Discharge Hose
1/2"	#10 Suction Hose

TIP When inserting hose into fitting, make certain hose can be seen in relief hole.



HOSE ROUTING

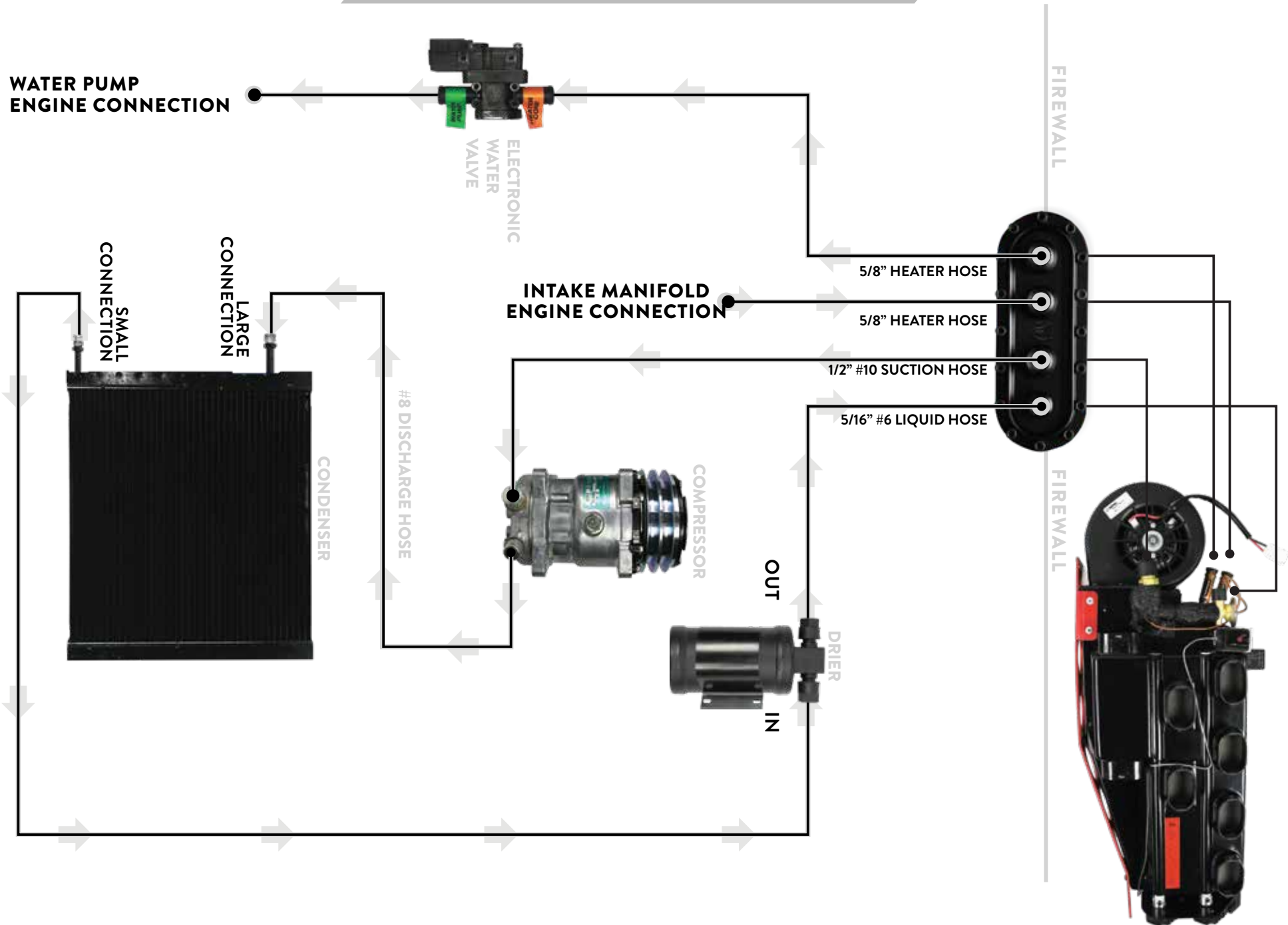

DRIER + PRESSURE SWITCH

PRESSURE SWITCH/SAFETY SWITCH (SINGLE SWITCH)

Remove the dust cover on the pressure switch and attach wiring harness to electrical connections. If properly installed, it will not allow the compressor to engage if too little or too much refrigerant.

Pressure switch is a compressor safety switch designed to save the compressor from failure due to too low or too high of pressure in the system.

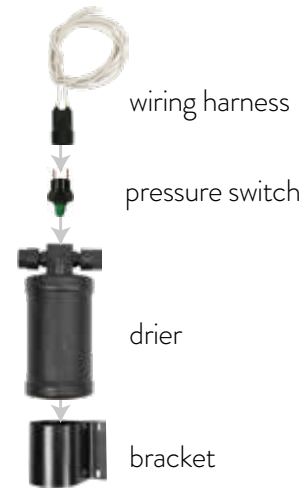
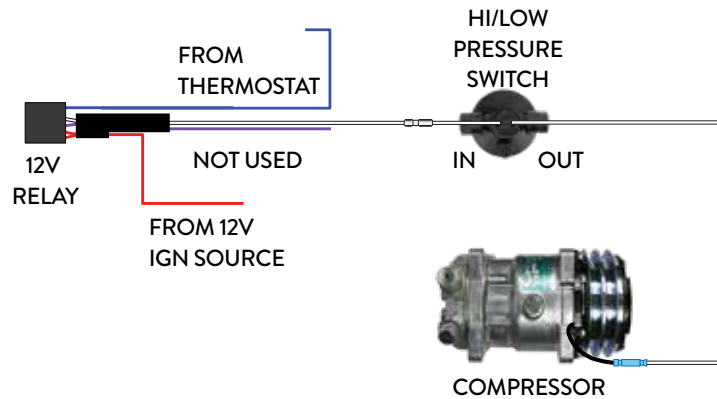

LOW	HIGH
28 PSI	- 380 PSI

	PRESSURE	SWITCH
RED	0-27 PSI	OPEN (OFF)
GREEN	28-380 PSI	CLOSED (ON)
RED	381+ PSI	OPEN (OFF)

IMPORTANT

When removing caps, pressure will release. Do **NOT** leave drier open to air longer than a couple minutes. Mount drier in a location where the hoses can reach.

TRINARY SWITCH (DUAL SWITCH)

Trinary switches combine low and high pressure compressor clutch cut-off functions plus an electric fan engagement signal at 254 psi.

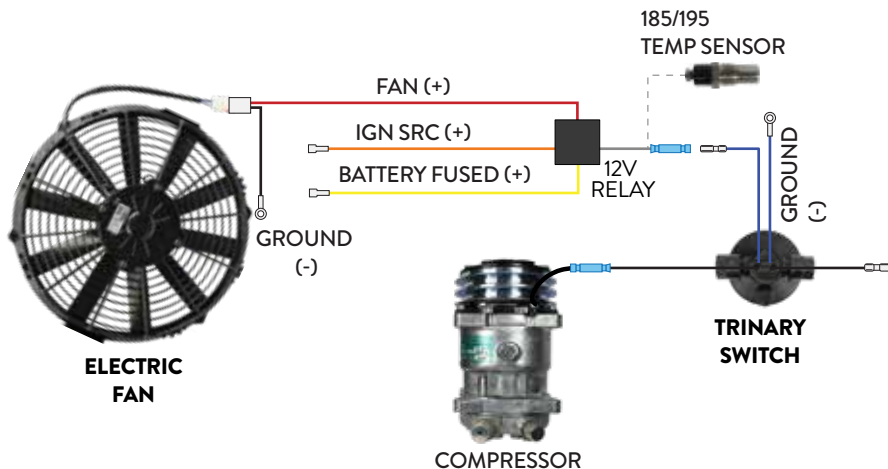

COMPRESSOR FUNCTION

	PRESSURE	SWITCH
RED	0-27 PSI	OPEN (OFF)
GREEN	28-380 PSI	CLOSED (ON)
RED	381+ PSI	OPEN (OFF)

ELECTRIC FAN FUNCTION

	PRESSURE	SWITCH
RED	0-253 PSI	OPEN (OFF)
GREEN	254+ PSI	CLOSED (ON)

DRIER TOP



